

FORD TRANSIT CUSTOM 2.2 TDCi - EURO5

Codice/Code: 622HDF0003FA

+ U003AA044

- (Kit Separatore Olio)
- (Kit Séparateur d'huile)
- (Oil Separator kit)
- (Ölabscheider-Einbausatz)
- (Oil Separator kit)

Abbinamento con DIAVIA FRIGO
Assemblage avec DIAVIA FRIGO
In combination with DIAVIA FRIGO
Mit DIAVIA FRIGO verbunden
Acoplamiento con DIAVIA FRIGO

Istruzioni di montaggio

Instructions pour le montage

Fitting instructions

Einbauanleitungen

Instrucciones de montaje

**DESCRIZIONE SIMBOLOGIA UTILIZZATA / DESCRIPTION DE LA SYMBOLOGIE UTILISÉE
DESCRIPTION OF SYMBOLS USED / BESCHREIBUNG DER VERWENDETEN SYMBOLIK
DESCRIPCIÓN DE LOS SIMBOLOS UTILIZADOS**

1A Riferimento a figura / Référence à la figure / See figure
In Bezug auf Abbildungen / Referencia a la figura

1-1 Riferimento a componenti di fornitura / Référence aux composants de la fourniture
See supplied components / Bezug auf Gelieferte Einbauelemente
Referencia a los componentes de abastecimiento

1 Riferimento a posizione schema elettrico / Référence à la position du schéma électrique
See position in wiring diagram / In Bezug auf Position im Schaltschema
Referencia a la posición del esquema eléctrico



- Lubrificare tutti i raccordi e gli O.R. con il nuovo olio refrigerante prima di collegarli

- Graisser tous les raccords et les O.R. avec le nouveau huile réfrigérant avant de les raccorder

-Lubricate all fittings and O-rings with new refrigerant oil before connecting them

- Alle Verbindungsstücke und OR-Ringe vor deren Verbindung mit dem neuen Kühlmittellöl ölen

- Lubrificar todos los empalmes y los O.R. con el nuevo aceite refrigerante antes de conectarlos

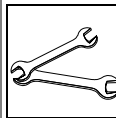

- Per avvitare a fondo o allentare i raccordi tubi gas usare due chiavi per bilanciare coppia di torsione

- Pour visser à fond ou desserrer les raccords des tuyaux gaz, utiliser le deux clés pour équilibrer le couple de torsion

- When tightening or loosening the fittings of the gas pipes, use two wrenches to equalize the torsion couple

- Um die Verbindungsstücke der Kältemittelschläuche gleichmäßig festzuschrauben oder zu lockern, zwei Schlüssel für das Verschraubungspaar verwenden

- Para enroscar a fondo o aflojar los empalmes tubos gas se deben usar dos llaves para balancear el par de torsión



- Tagliare con utensile appropriato al materiale

- Couper à l'aide d'outil approprié

- Cut with a device suitable for the material

- Mit dem Material entsprechendem Werkzeug schneiden

- Cortar con herramienta apropiada al material

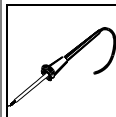
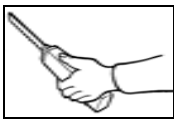

- Stagnare

- Étamer

- Tin

- Verzinnen

- Estañar



- Spianare

- Nivelar

- Flatten out

- Richten

- Nivelar

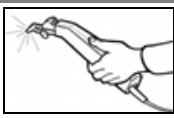

- Tagliare con utensile a lama calda

- Couper à l'aide d'un outil à lame chaude

- Cut using the tool with heated blade.

- Mit Schweißmesserwerkzeug schneiden

- Cortar con útil a hoja caliente

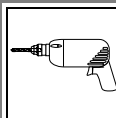

- Forare

- Percer

- To drill

- Durchbohren

- Taladrar

Pos.	ITALIANO	FRANÇAIS	ENGLISH	DEUTSCH	ESPAÑOL
C	Compressore	Compresseur	Compressor	Kompressor	Compresor
2	Flangia tubi gas	Bride tuyaux gaz	Gas pipe flange	Kältemittelschlauchhflansch	Brida tubos gas
31	Condensatore elettroventilato	Condenseur avec ventilateur	Condenser with fan	Elektrobelüftete Kondensator	Condensador electroventilado
32	Sacchetto accessori	Sachet accessoires	Bag of accessories	Säckchen mit Zuberhörteilen	Bolsita accesorios
33	Staffa sinistra di supporto condensatore e filtro essiccatore	Etrier gauche de support condensateur et filtre de séchage	Left support bracket for condenser and receiver drier	Linker Kondensator und Trocknerfilter Haltebügel	Estrizo izquierdo de soporte condensador y filtro secador
34	Staffa destra di supporto condensatore	Etrier support condenseur droit	Right condenser support bracket	Kondensator Haltebügel, rechts	Abrazadera derecha de soporte condensador
35	Elettroventola	Electroventilateur	Electric fan	Elektrogebläse	Electroventilador
36	Staffa di supporto elettroventola	Etrier de support électroventilateur	Electric fan support bracket	Elektrogebläse Haltebügel	Abrazadera de soporte electroventilador
37	Staffa di rinforzo elettroventola	Étrier de renforcement électroventilateur	Electric fan reinforcing bracket	Elektrogebläsestütze	Abrazadera de refuerzo electroventilador
38	Resistore	Résisteur	Resistor	Widerstand	Resistor
39	Staffa supporto resistore	Etrier de support résisteur	Resistor support bracket	Widerstand Haltebügel	Abrazadera de soporte resistor
40	Inserto filettato M5	Pièce d'insertion filetée M5	Threaded insert M5	Gewindeinsatz M5	Encastre fileteado M5
41	Fascetta in gomma	Collier en caoutchouc	Rubber clamp	Gummischelle	Banda de goma
42-43	Staffa	Etrier	Bracket	Bügel	Abrazadera
45	Protezione relay	Couvre-relais	Relay cover	Relais-Verkleidung	Cubre relais
51	Filtro essiccatore	Filtre déshydrateur	Receiver drier	Trocknerfilter	Filtro secador
52	Pressostato	Pressostat	Pressure switch	Druckwächter	Presostato
54	Sacchetto accessori per separatore olio	Sachet accessoires pour séparateur huile	Bag of accessories for oil separator	Säckchen mit Zuberhörteilen für Ölabscheider	Bolsita accesorio para separador aceite
55	Separatore olio	Séparateur huile	Oil separator	Ölabscheider	Separador aceite
56	Staffa separatore olio	Etrier séparateur huile	Oil separator bracket	Ölabscheiderbügel	Abrazadera separadora aceite
60	Sacchetto fissaggio tubi gas	Sachet fixation tuyaux gaz	Bag of gas pipe securing elements	Säckchen mit Kältemittelschlauch-Befestigung	Bolsita sujeción tubos gas

<i>Pos.</i>	<i>ITALIANO</i>	<i>FRANÇAIS</i>	<i>ENGLISH</i>	<i>DEUTSCH</i>	<i>ESPAÑOL</i>
60.1	Protezione a spirale	Protection en spirale	Spiral protection	Spiralförmige Ummantelung	Protección a espiral
60.2	Fascetta fissatubo a 2 vie	Collier de fixation tuyau à 2 voies	2-way hose clamp	Befestigungsschelle des 2-weg Schlauchs	Banda fijación tubo a 2 vías
60.3 60.4 60.5	Fascetta in gomma	Collier en caoutchouc	Rubber clamp	Gummischelle	Banda de goma
72A	Sede comandi personalizzata	Logement de commandes personnalisées	Customized control housing	Persönlich gestalterter Steuerungssitz	Caja mandos personalizada
76-77	Contentitore olio	Révoir huile	Oil tank	Ölbehälter	Contenedor aceite
106	Impianto elettrico Elettroventole	Installation électrique electroventilateurs	Fans electric system	Elektrische Anlage Elektrolüfter	Instalación eléctrica electroventiladores
107	Giunzione RAYCHEM BLU	Raccord RAYCHEM BLEU	BLUE RAYCHEM connector	RAYCHEM Verbindung BLAU	Junta RAYCHEM TURQUI
111	Impianto elettrico intermedio	Faisceau électrique intermédiaire	Intermediate wiring system	Elektrische Zwischenanlage	Instalación eléctrica intermedia
111.1	Gommino passacavi	Pièce en caoutchouc passe-câbles	Rubber wires lead	Kabeldurchgang	Goma pasacables
118	Sacchetto raccordi	Sachet raccords	Bag of findings	Säckchen mit Verbindungsstücken	Bolsita racores
119 120 121	Tubo gas	Tuyau gaz	Gas hose	Kältemittelschlauch	Tubo gas
122 123 124	Fascetta per raccordi tubi gas	Collier pour raccords tuyaux gaz	Clamp for gas hose connection	Schelle für Verbindungsstücke der Kältemittelschläuche	Banda para racores tubos gas
125 ↓ 136	Raccordo tubo gas	Raccord tuyau gaz	Gas hose connection	Kältemittelschlauchverbindungsstück	Racor tubo gas
K	Raccordo con punto di carica	Raccord avec point de charge	Charge point connection	Verbindungsstück mit Füllpunkt	Racor con punto de carga
	Fascetta a strappo	Bride auto-bloquant	Self-locking clamp	Selbstsichernde Schelle	Banda autobloqueante

**MONTAGGIO COMPRESSORE / POSE DU COMPRESSEUR / COMPRESSOR FITTING
KOMPRESSOREINBAU / MONTAJE COMPRESOR**

MATERIALE FORNITO / MATERIEL FOURNI / SUPPLIED MATERIAL / GELIEFERTES MATERIAL / MATERIAL ABASTECIDO

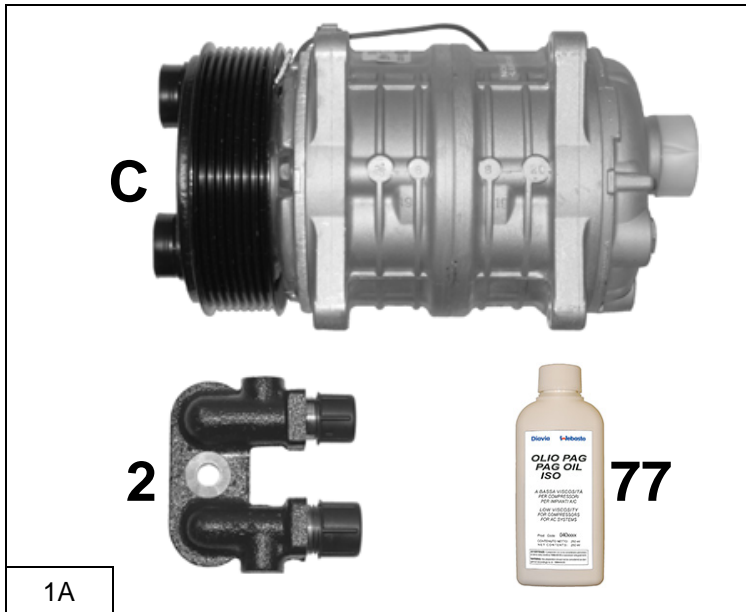

Pos.	Descrizione / Description / Description Beschreibung / Descripción	Codice / Code Kode / Código
C	Compressore	015273/0
2	Flangia tubi gas	043590/0
77	Contenitore olio (Pag ISO 46)	040595/1

(I)
ATTENZIONE:
Le operazioni di montaggio del compressore, sono illustrate nel manuale di istruzioni fornito unitamente al KIT COMPRESSORE, a cui si rimanda l'installatore.

(F)
ATTENTION:
Les opérations de montage du compresseur, sont illustrées dans le manuel d'instruction fourni avec KIT COMPRESSEUR, auquel se reporte l'installateur.

(GB)
WARNING:
See the instruction manual supplied with the COMPRESSOR KIT for instructions on the operations involved in installing the Compressor.

(D)
ACHTUNG:
Die Einbauschritte der Kompressor sind im mitgelieferten Anleitungshandbuch der KOMPRESSOR KIT Einheit dargestellt und vom Einbauer einzuhalten.

(E)
ATENCIÓN:
Las operaciones de montaje del compresor se ilustran en el manual de instrucciones suministrado con el KIT COMPRESOR, el cual debe ser consultado por el instalador.

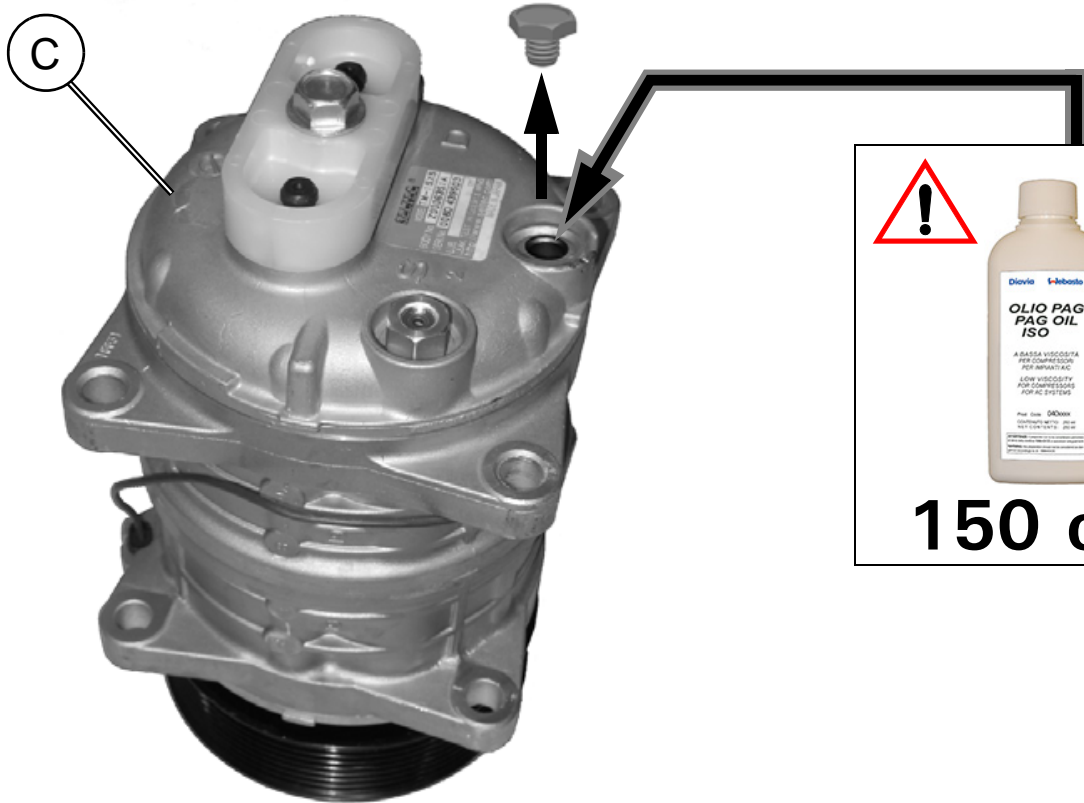

(I)
ATTENZIONE:

E' necessario inserire all'interno del compressore, prima di installarlo, la quantità indicata di olio fornito "77".



(F)
ATTENTION:

Il est nécessaire d'insérer à l'intérieur du compresseur, avant de l'installer, la quantité indiquée d'huile "77" qui est fourni.



(GB)
WARNING:

Before installation, add the indicated amount of supplied oil "77" to the compressor.



(D)
ACHTUNG:

Sie müssen innerhalb der Kompressor vor der Installation eingeben, die Menge der Öl versorgt "77".



(E)
ATENCIÓN:

Es necesario echar dentro del compresor, antes de instalarlo, la cantidad indicada del aceite suministrado "77".

**MONTAGGIO CONDENSATORE-FILTRO ESSICCATORE / POSE DU CONDENSEUR-FILTRE DESHYDRATEUR
CONDENSER-RECEIVER DRIER FITTING / KONDENSATOR-TROCKNERFILTER EINBAU
MONTAJE CONDENSADOR-FILTRO SECADOR**

MATERIALE FORNITO / MATERIEL FOURNI / SUPPLIED MATERIAL / GELIEFERTES MATERIAL / MATERIAL ABASTECIDO

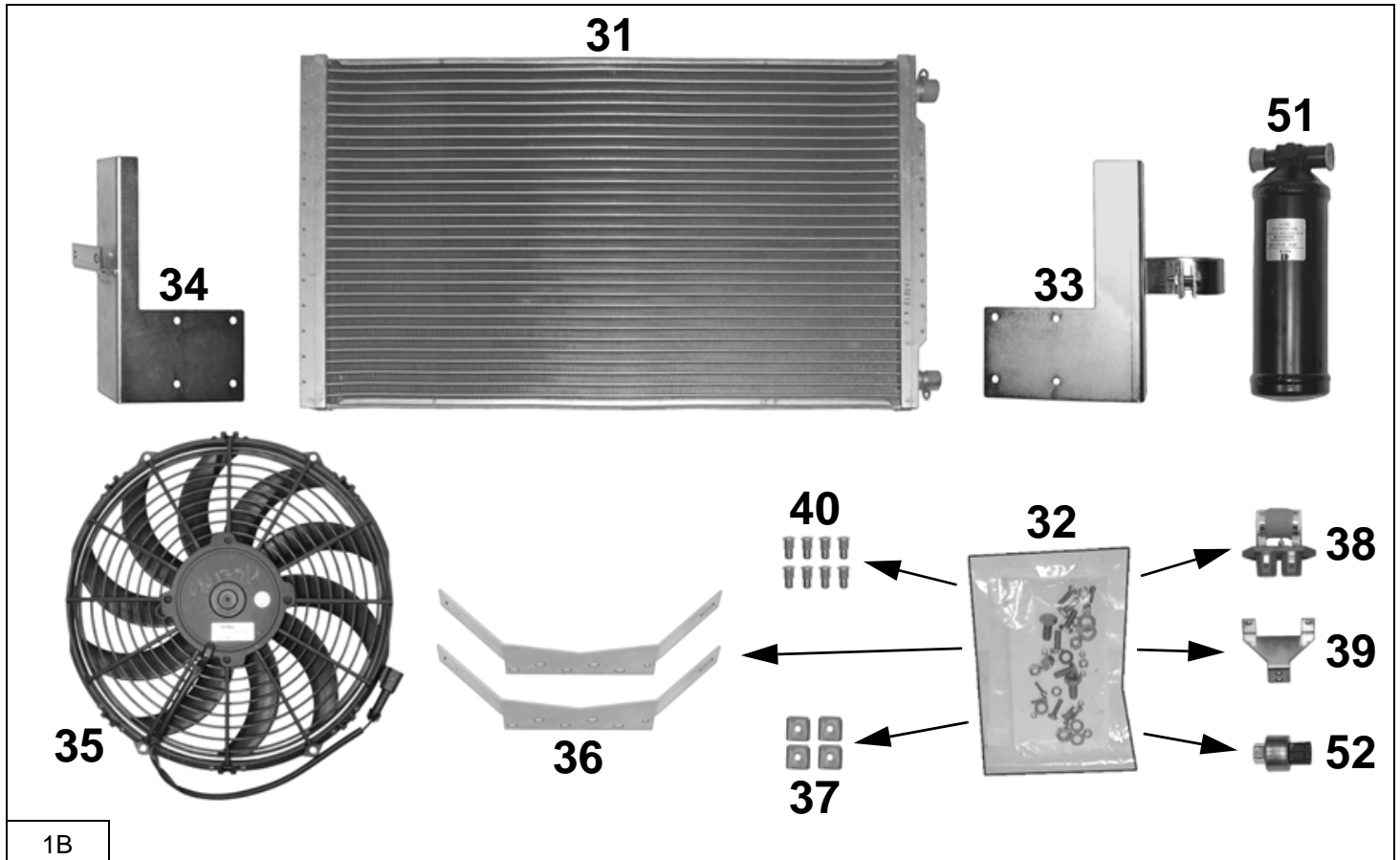

1B

Pos.	Descrizione / Description / Description Beschreibung / Descripción	Codice / Code Kode / Código
31	Condensatore	022301OR/1
32	Sacchetto accessori	0232171/0
33	Staffa sinistra di supporto condensatore e filtro essiccatore	0813127/0
34	Staffa destra di supporto condensatore	0813126/0
35	Elettroventola	080135.1
36	Staffa di supporto elettroventola	0811423/0
37	Staffa di rinforzo elettroventola	036124.1
38	Resistore	0682787/0
39	Staffa supporto resistore	081714/1
40	Inserto filettato M5	062105/0
51	Filtro essiccatore	017047/1
52	Pressostato	043181/0

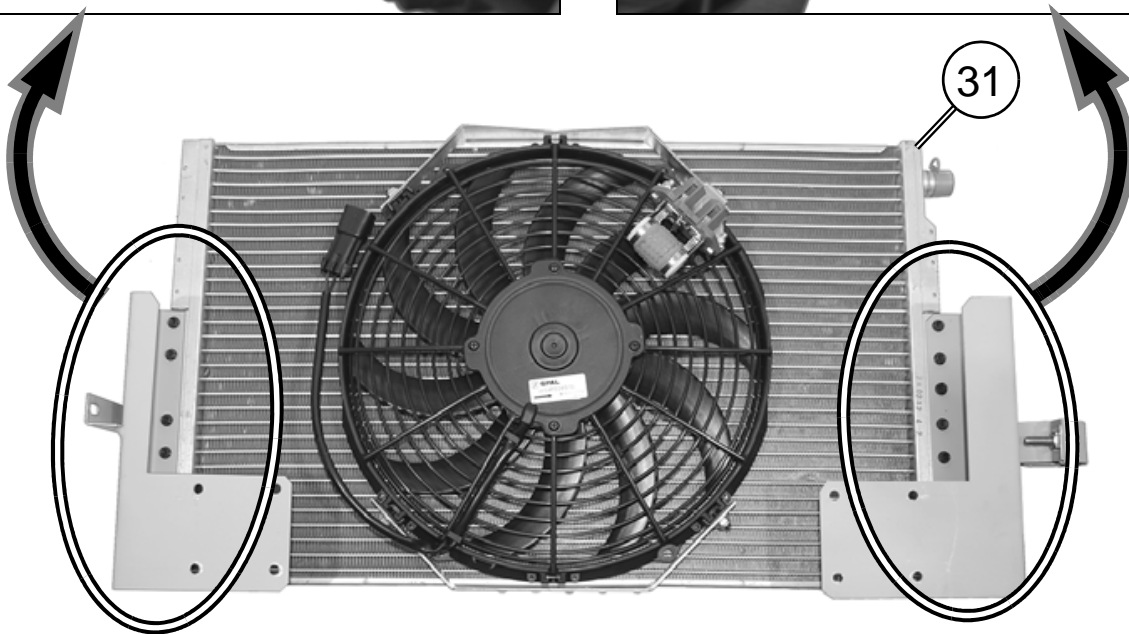
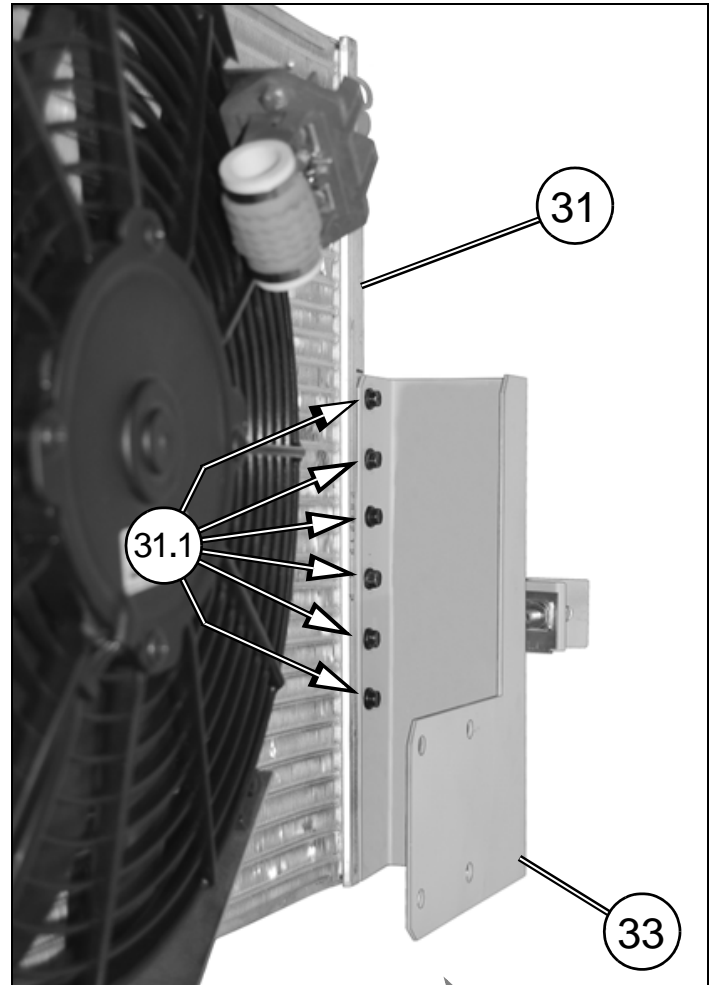
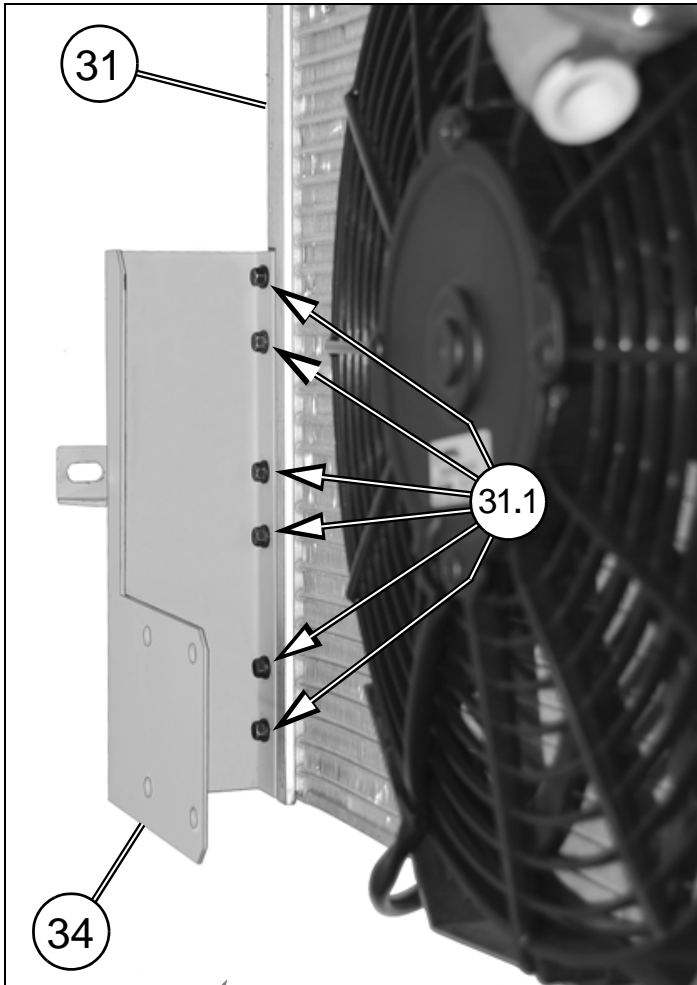



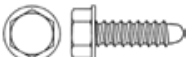

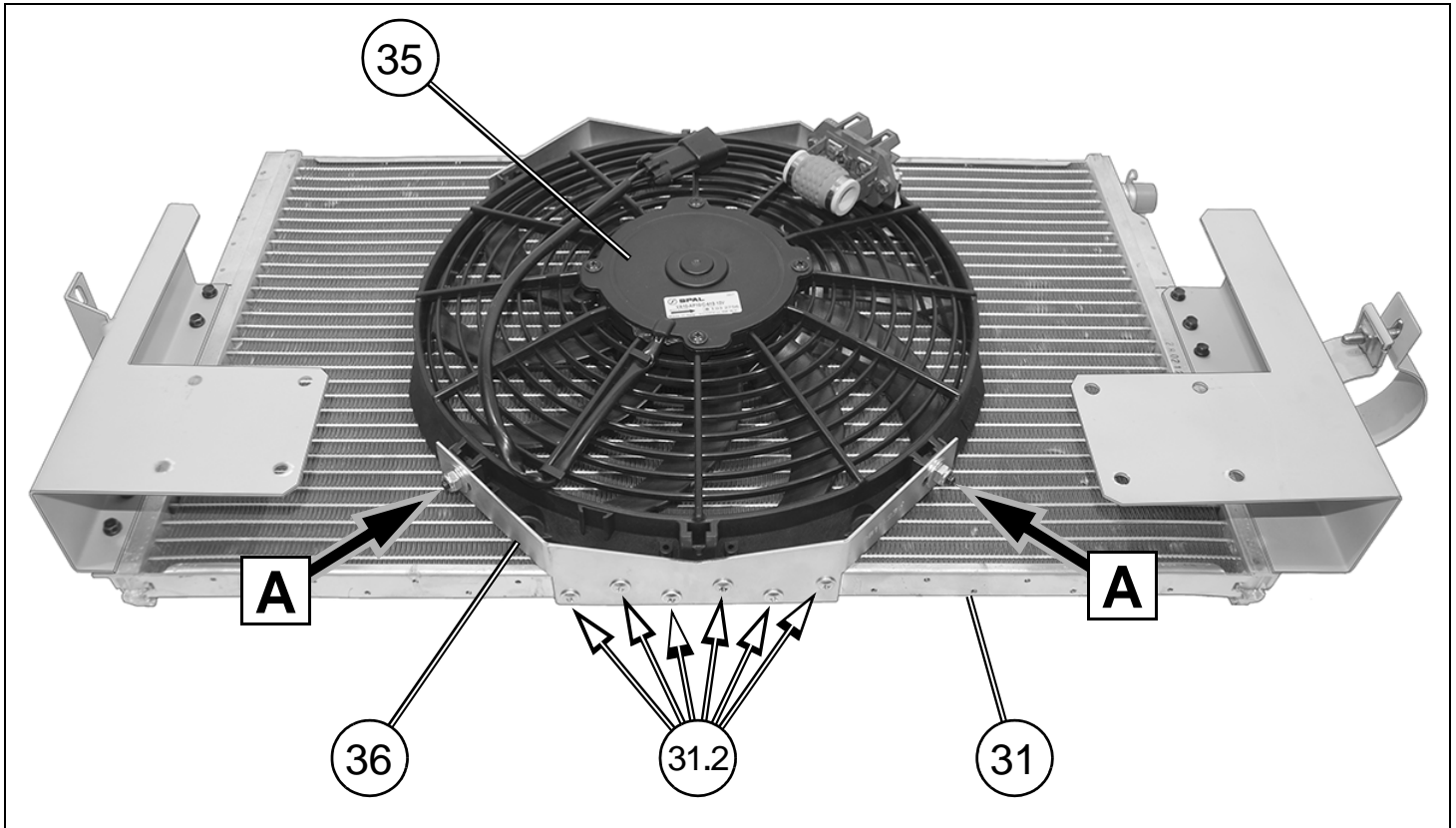
2B

ELEMENTI DI FISSAGGIO / PIÈCES DE FIXATION / FIXING PARTS BEFESTIGUNGSELEMENTE / ELEMENTOS DE FIJACION		
Pos.	Tipologia / Typologie / Typology Tipologie / Tipologia	Descrizione / Description / Description Beschreibung / Descripción
31.1		4,2 x 13



3B

ELEMENTI DI FISSAGGIO / PIECES DE FIXATION FIXING PARTS / BEFESTIGUNGSELEMENTE ELEMENTOS DE FIJACION		
Pos.	Tipologia / Typologie Typology / Tipologie Tipologia	Descrizione / Description Description / Beschreibung Descripción
31.2		4,2 x 9,5
35.1		M6 x 16
35.2		ϕ 6 x ϕ 18 x 2
35.3		M6

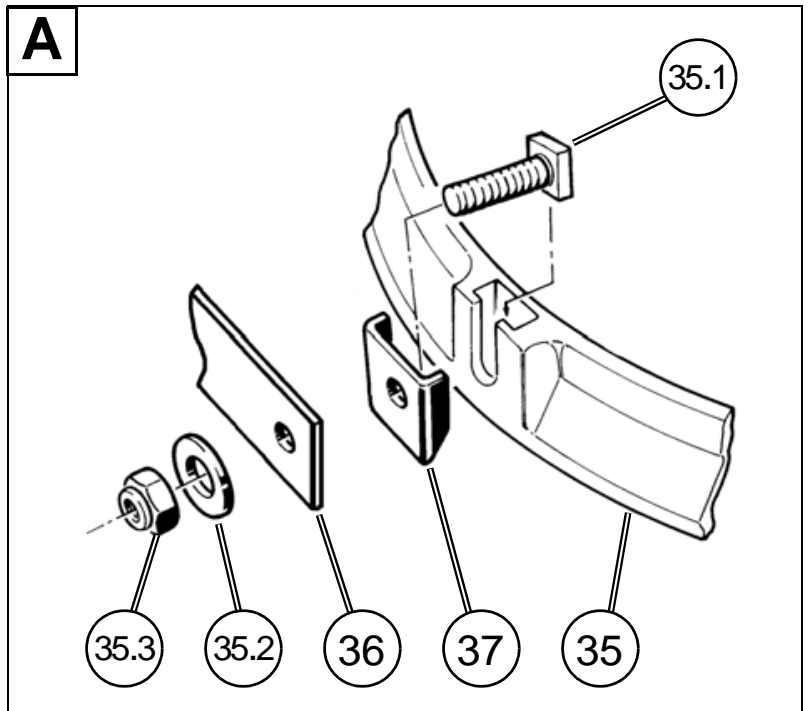

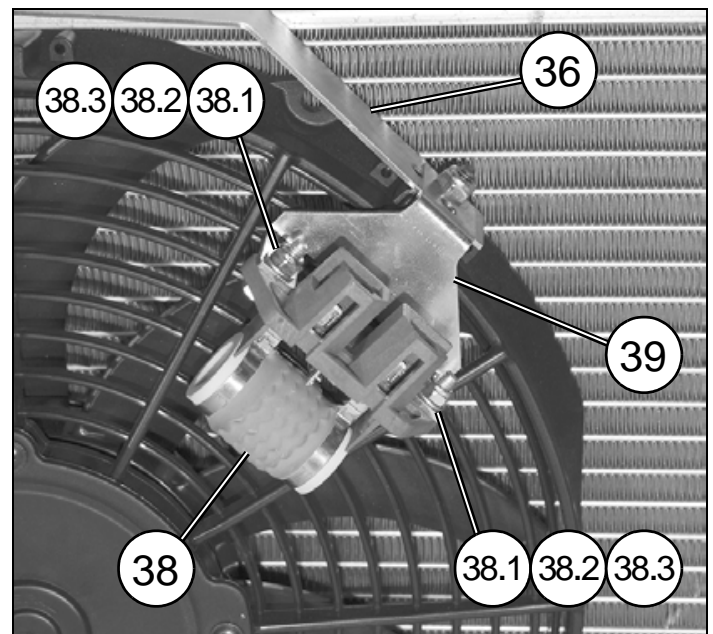
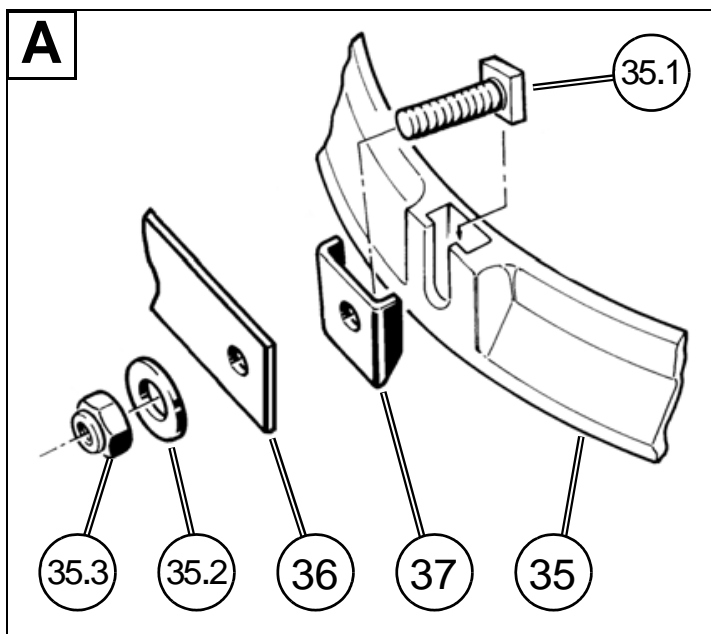
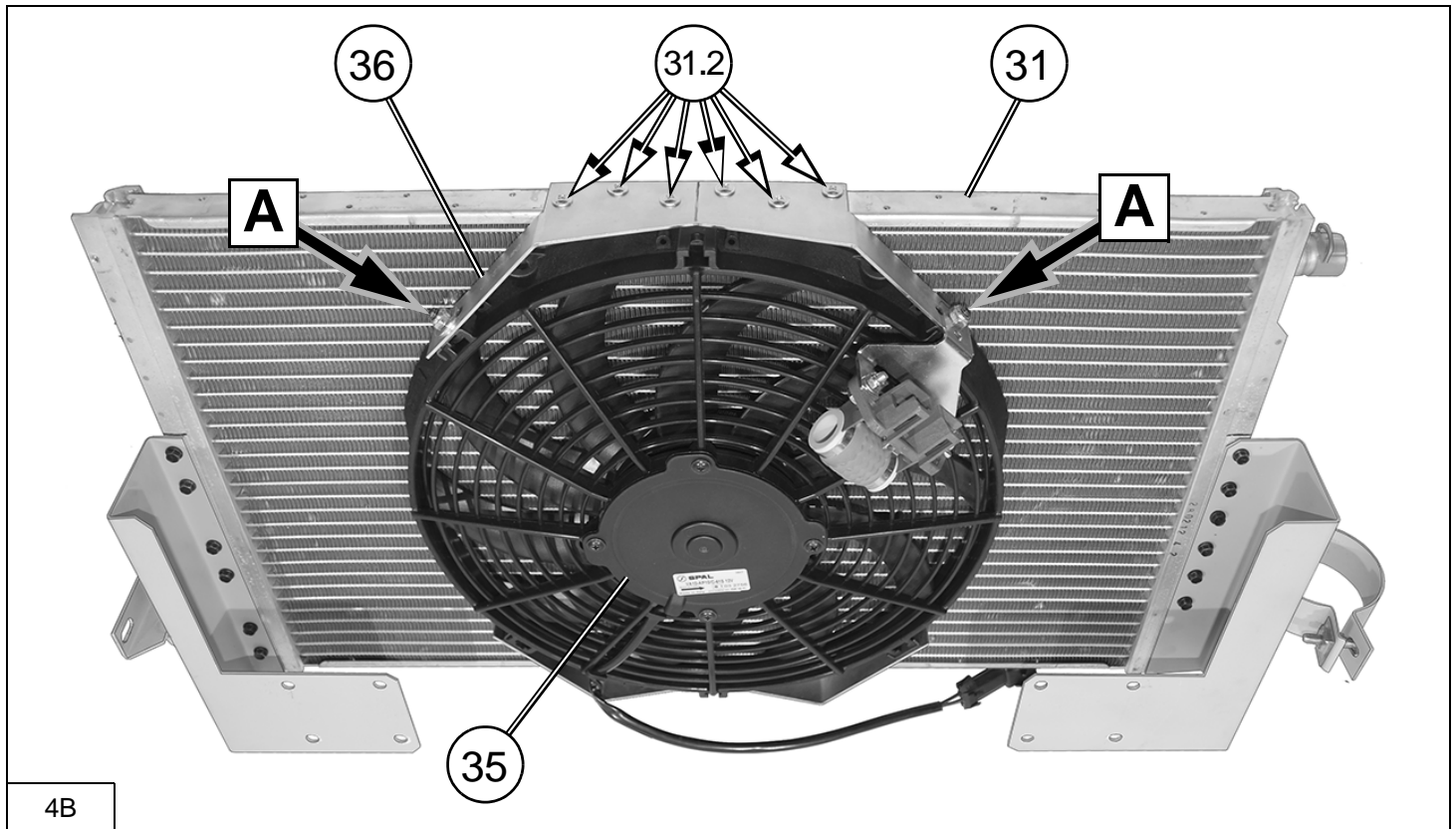

ELEMENTI DI FISSAGGIO / PIECES DE FIXATION / FIXING PARTS BEFESTIGUNGSELEMENTE / ELEMENTOS DE FIJACION		
Pos.	Tipologia / Typologie / Typology Tipologie / Tipologia	Descrizione / Description / Description Beschreibung / Descripción
31.2		4,2 x 9,5
35.1		M6 x 16
35.2		ϕ 6 x ϕ 18 x 2
35.3		M6

ELEMENTI DI FISSAGGIO / PIECES DE FIXATION / FIXING PARTS BEFESTIGUNGSELEMENTE / ELEMENTOS DE FIJACION		
Pos.	Tipologia / Typologie / Typology Tipologie / Tipologia	Descrizione / Description / Description Beschreibung / Descripción
38.1		M5 x 16
38.2		ϕ 5
38.3		M5

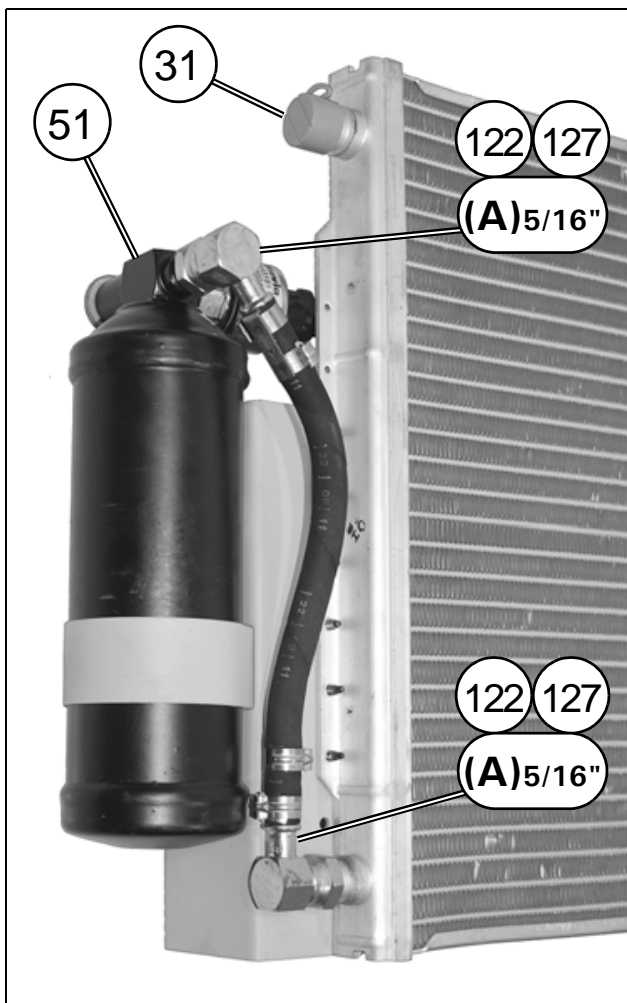
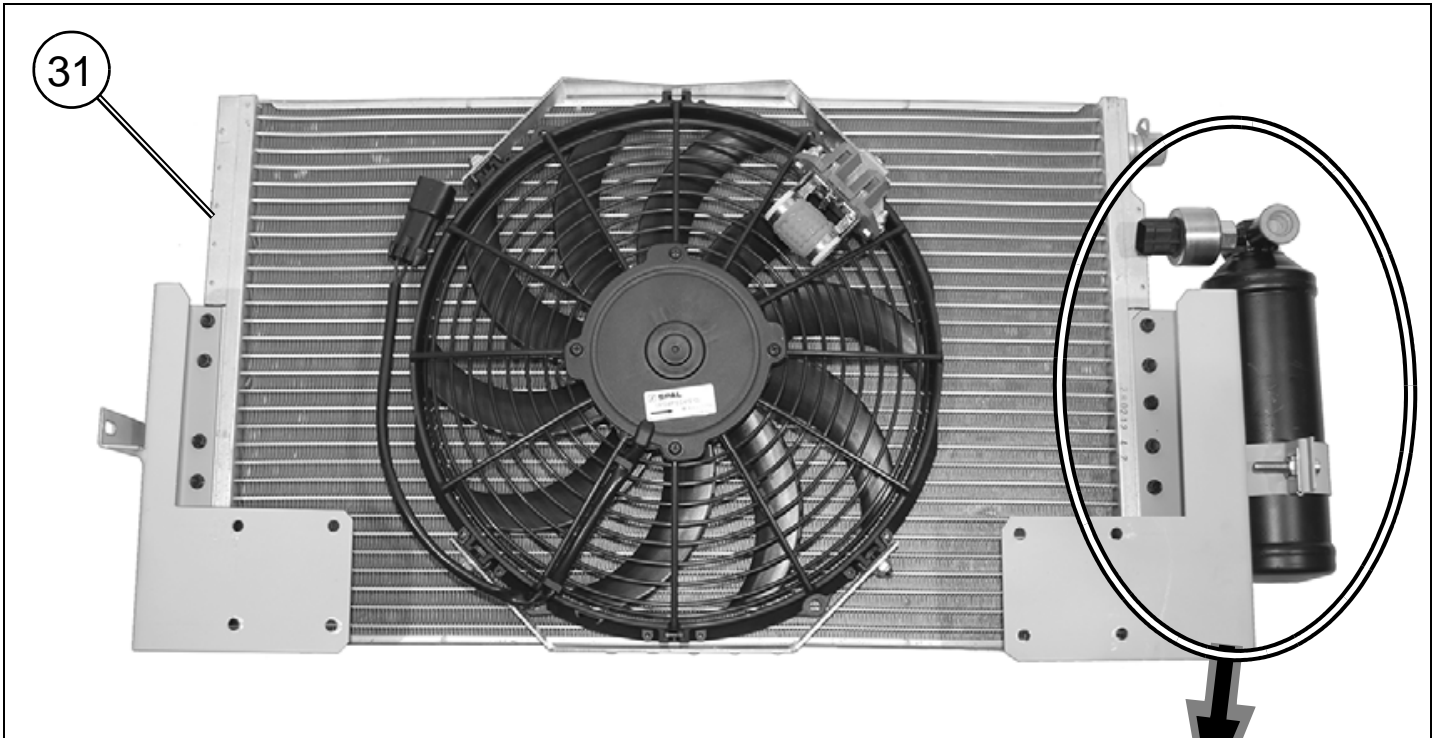



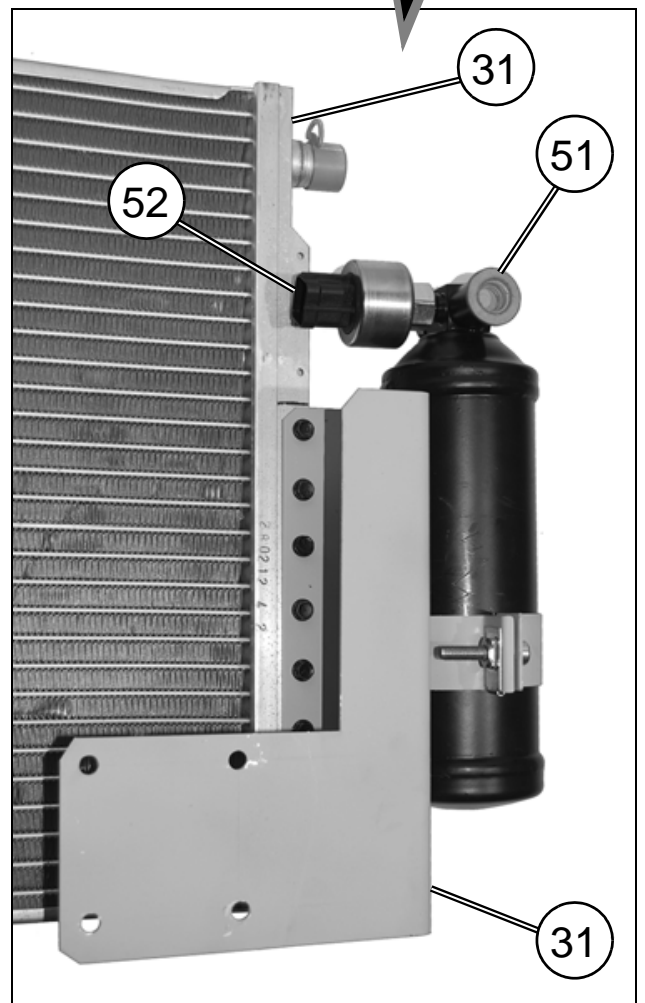

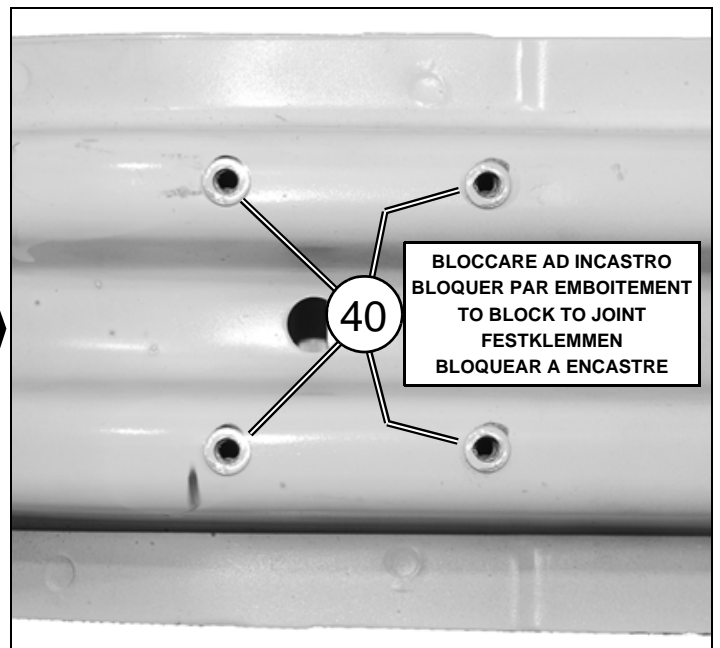
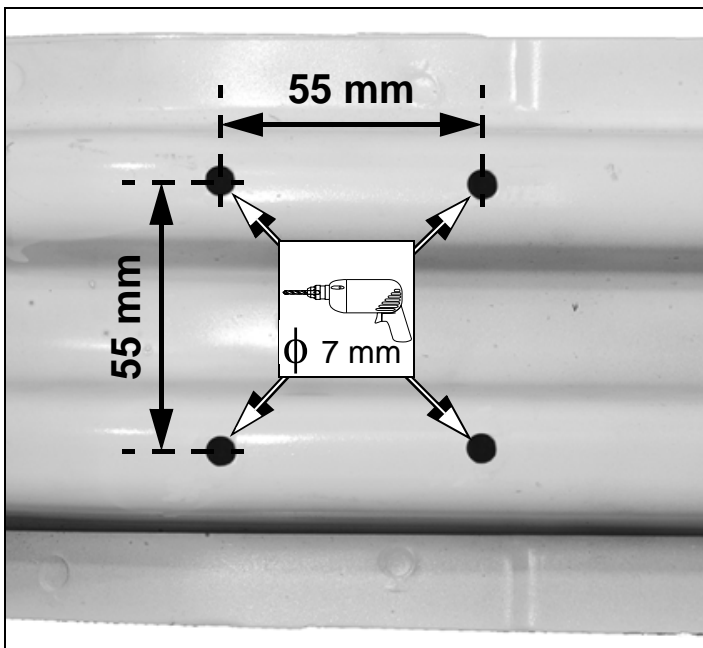
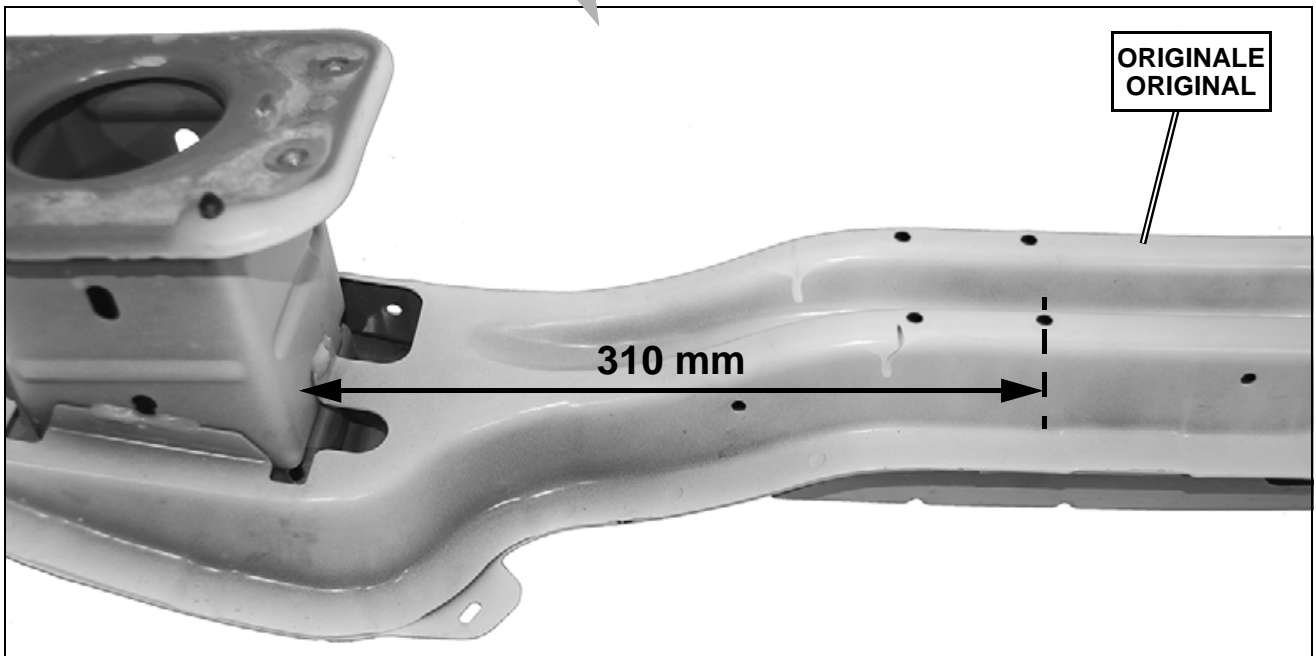
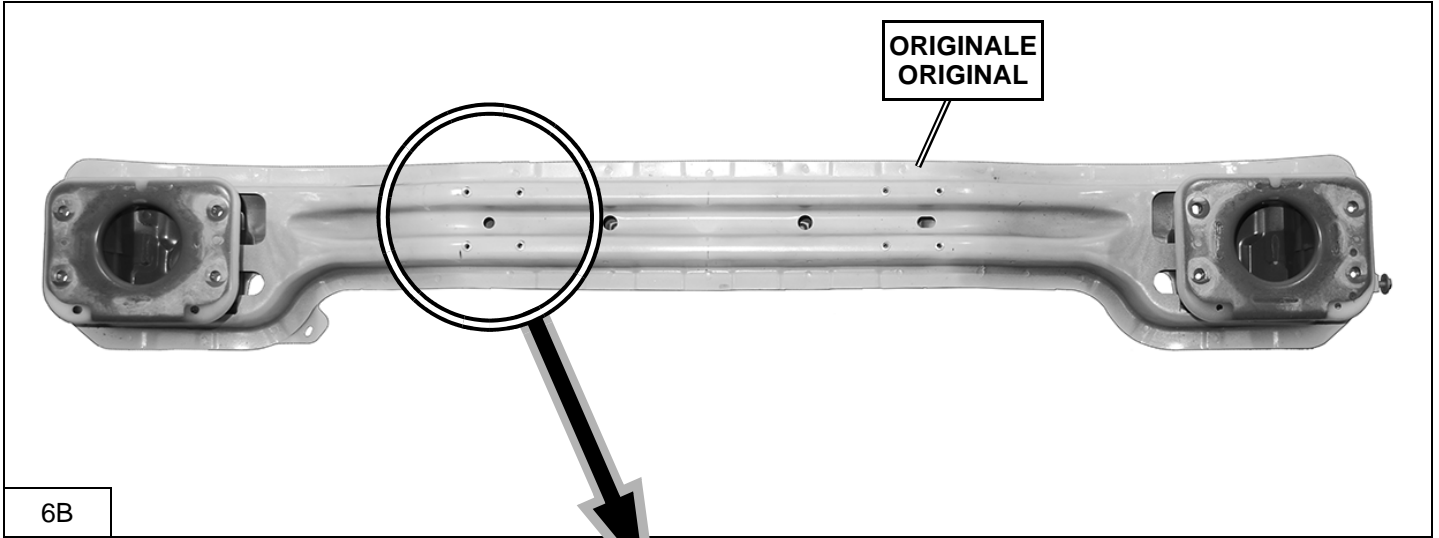
5B

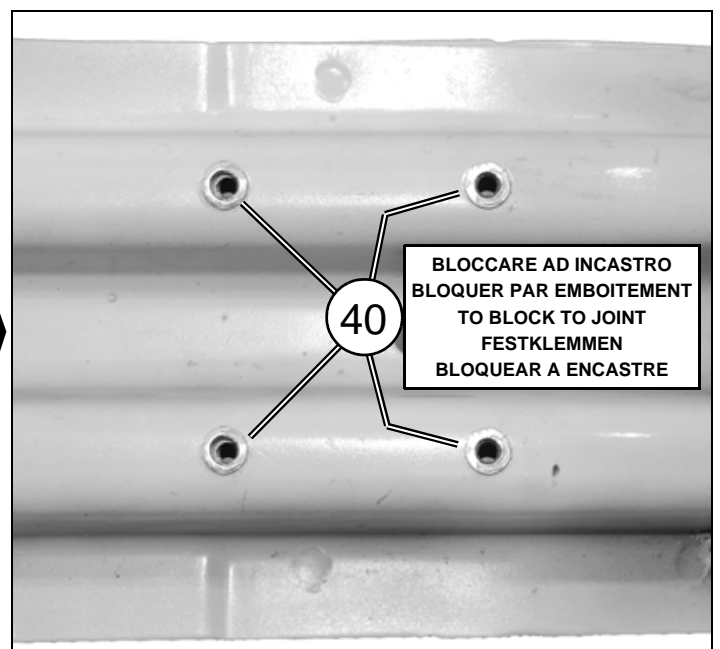
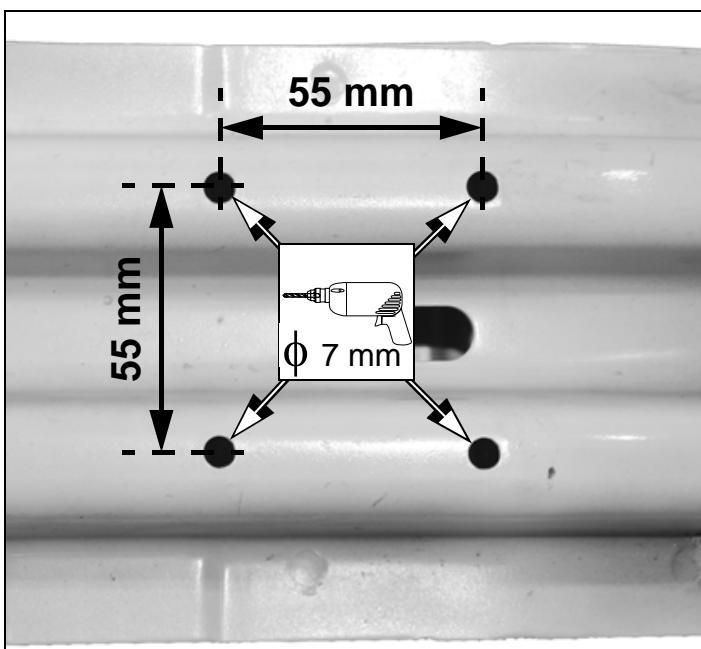
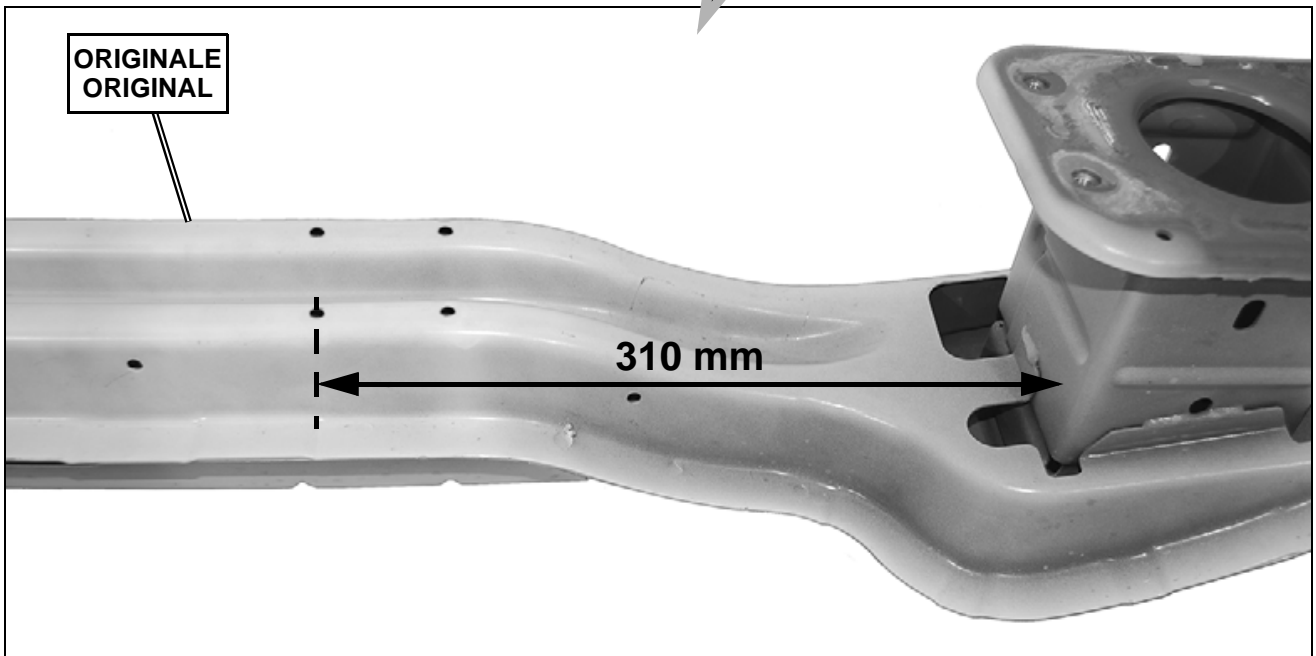
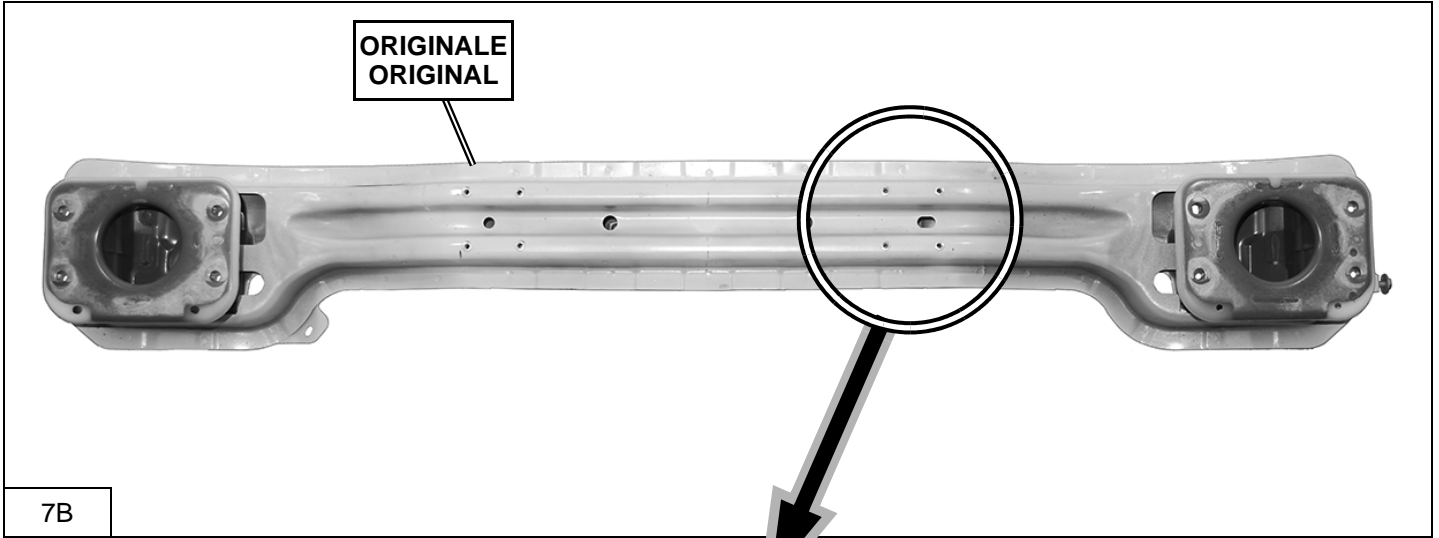

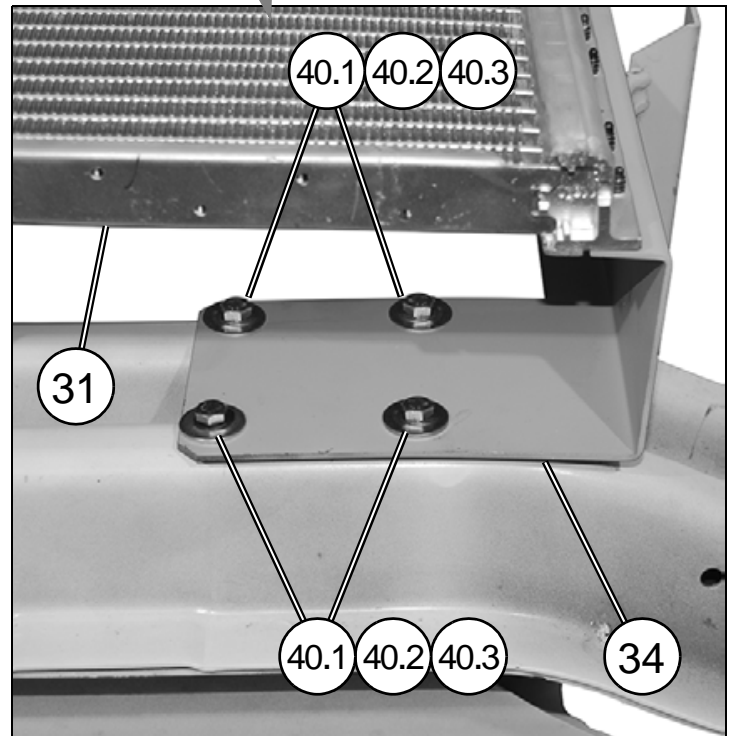
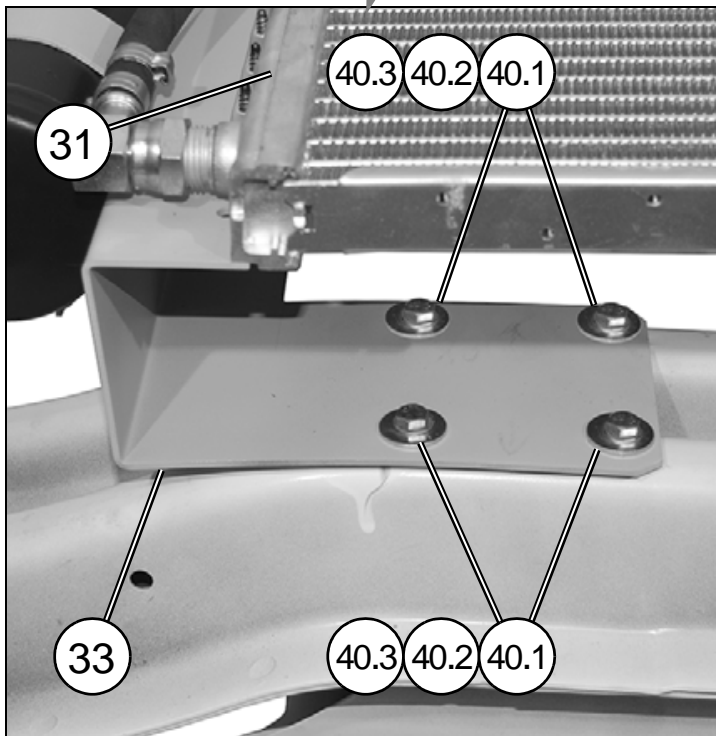
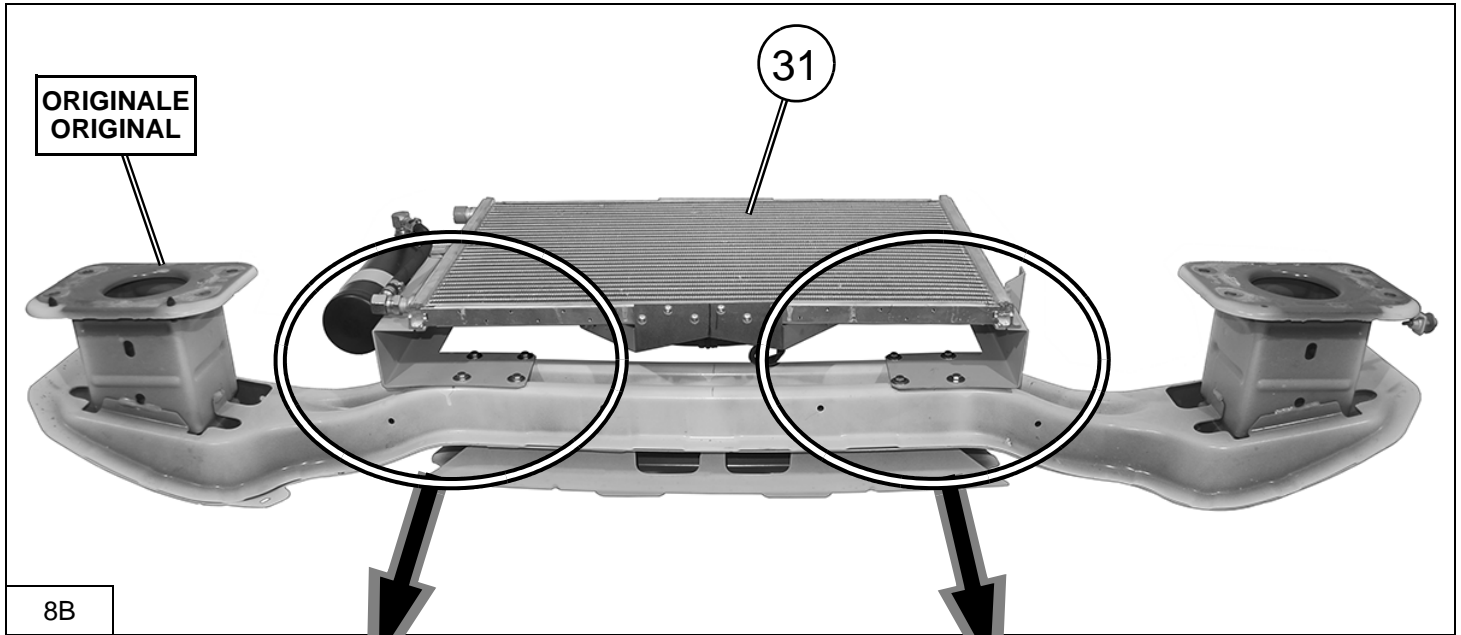





ELEMENTI DI FISSAGGIO / PIÈCES DE FIXATION / FIXING PARTS BEFESTIGUNGSELEMENTE / ELEMENTOS DE FIJACION		
Pos.	Tipologia / Typologie / Typology Tipologie / Tipologia	Descrizione / Description / Description Beschreibung / Descripción
40.1		M5 x 15
40.2		φ 5
40.3		φ 5 x φ 15 x 1,5

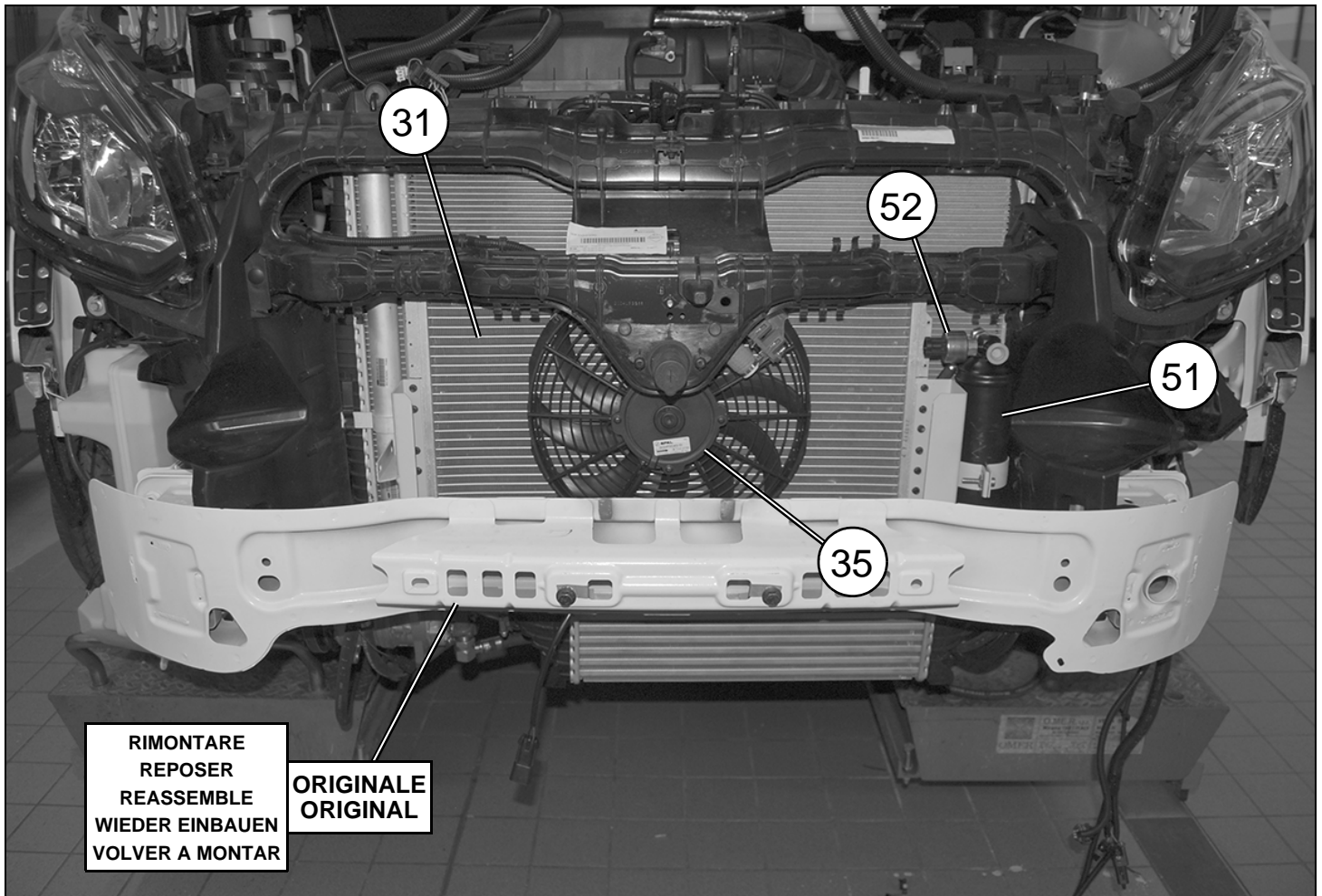

9B

**MONTAGGIO SEPARATORE OLIO / MONTAGE SEPARATEUR HUILE / INSTALLATION OF OIL SEPARATOR
EINBAU DES OELABSCHIEDERS / MONTAJE SEPARADOR ACEITE**

Componenti forniti a richiesta con **Kit U003AA044** - (vedi anche fig. 3.2F).
 Composants fournis à la demande avec **Kit U003AA044** - (voir aussi fig. 3.2F).
 Components supplied upon request with **Kit U003AA044** - (also see the fig. 3.2F).
 Auf Anfrage mit **Einbausatz U003AA044** gelieferte Einbauteile - (siehe auch abb. 3.2F).
 Componentes suministrados con **kit U003AA044** bajo petición - (véase también fig.3.2F).

MATERIALE FORNITO / MATERIEL FOURNI / SUPPLIED MATERIAL / GELIEFERTES MATERIAL / MATERIAL ABASTECIDO

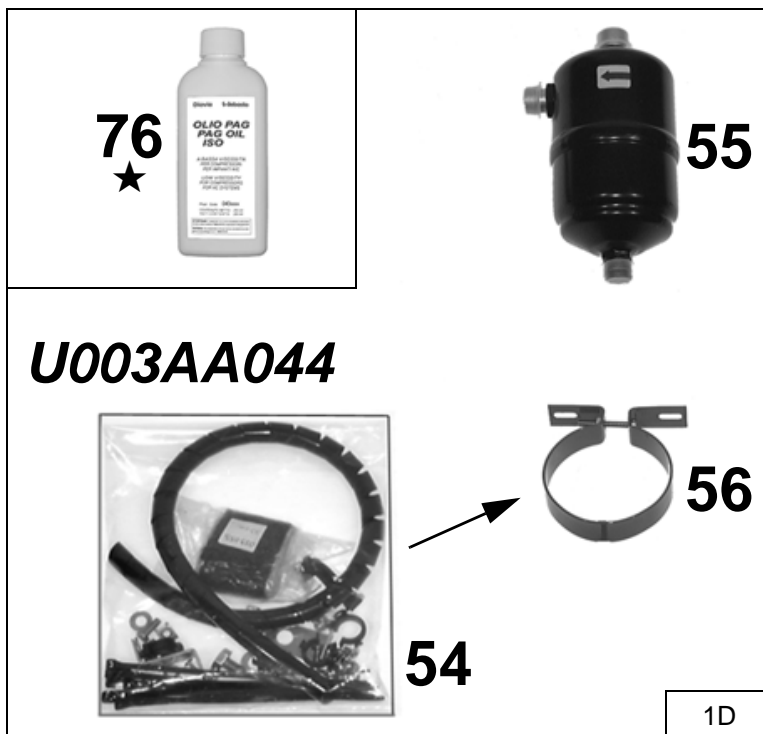

Pos.	Descrizione / Description Description / Beschreibung Descripción	Codice / Code Kode / Código
54	Sacchetto accessori per separatore olio	0231654/0
55	Separatore olio	043265/0
56	Staffa separatore olio	0601499/0
76★	Contenitore olio	-
★	Componente fornito nel Kit DIAVIA FRIGO Composant fourni dans le kit DIAVIA FRIGO Component supplied in KIT DIAVIA FRIGO Mit Einbausatz DIAVIA FRIGO gelieferte Einbauteile Componente abastecido en el KIT DIAVIA FRIGO	

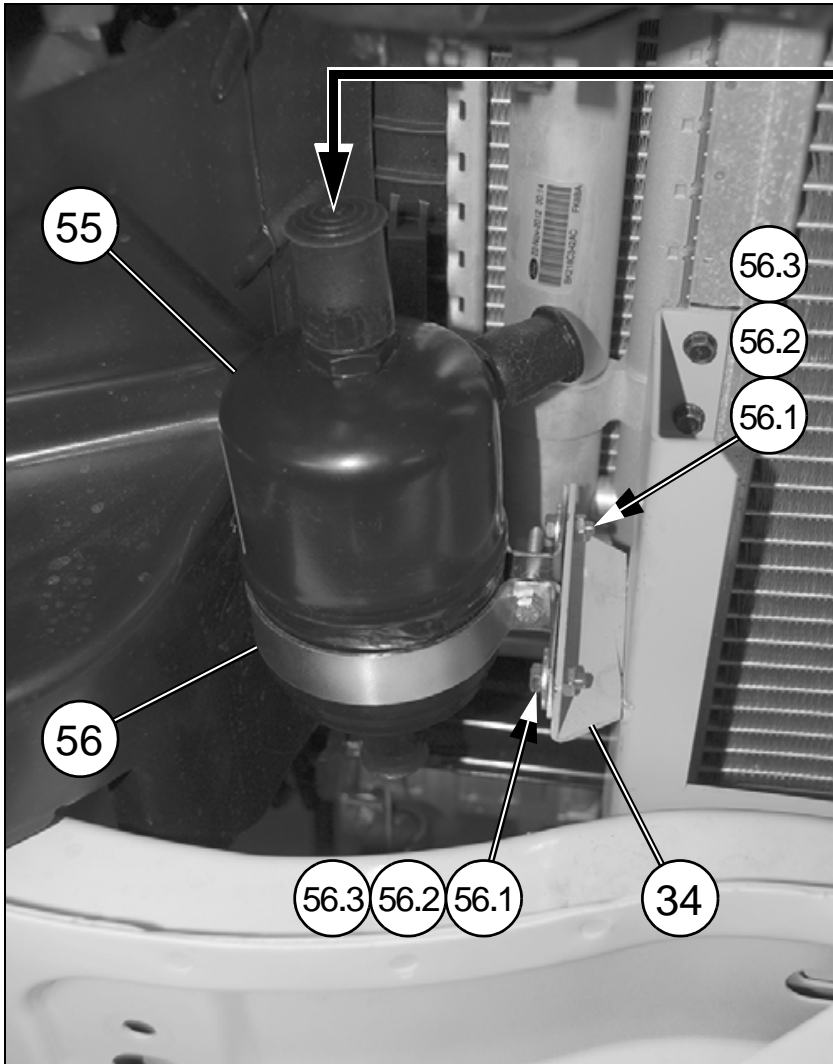

150c.c.

2D

ELEMENTI DI FISSAGGIO / PIECES DE FIXATION / FIXING PARTS BEFESTIGUNGSELEMENTE / ELEMENTOS DE FIJACION		
Pos.	Tipologia / Typologie / Typology Tipologie / Tipologia	Descrizione / Description / Description Beschreibung / Descripción
56.1		M5 x 16
56.2		φ 5
56.3		M5

**MONTAGGIO GRUPPO REFRIGERANTE / POSE DU GROUPE REFRIGERANT
REFRIGERANT UNIT ASSEMBLY FRIGOSOFT / EINBAU DER KÜHLEINHEIT
MONTAJE E INSTALACIÓN DEL GRUPO REFRIGERANTE**

(I)
ATTENZIONE:
*Le operazioni di montaggio dell'unità refrigerante e del gruppo comando con utilizzo del supporto standard, sono illustrate nel manuale di istruzioni fornito unitamente al gruppo DIAVIA FRIGO, a cui si rimanda l'installatore.
Nelle pagine seguenti è illustrato la soluzione alternativa di montaggio del gruppo comando con utilizzo della sede personalizzata "72A" fornita nel presente impianto base.*

(F)
ATTENTION:
*Les opérations de montage de l'unité réfrigérante et du groupe de commande utilisant le support standard, sont illustrées dans le manuel d'instruction fourni avec le groupe DIAVIA FRIGO, auquel se reporte l'installateur.
Dans les pages suivantes la solution alternative de montage du groupe de commande utilisant le logement personnalisé "72A" fourni dans l'installation de base présente est illustré.*

(GB)
WARNING:
*See the instruction manual supplied with the DIAVIA FRIGO unit for instructions on the operations involved in installing the refrigerating unit and the controls using the standard support.
The pages below illustrate the alternate installation of the controls using the customized housing "72A" provided in the present basic system.*

(D)
ACHTUNG:
*Die Einbauschritte der Kühlungseinheit und der Steuerungsgruppe unter Verwendung der Standardträger sind im mitgelieferten Anleitungshandbuch der DIAVIA FRIGO Einheit dargestellt und vom Einbauer einzuhalten.
Auf den folgenden Seiten ist eine alternative Einbaumöglichkeit der Steuerungsgruppe im persönlich gestalteten und mit der Grundausstattung gelieferten Sitz "72A" dargestellt*

(E)
ATENCIÓN:
*Las operaciones de montaje de la unidad refrigerante y del grupo de mando que utilizan el soporte estándar se ilustran en el manual de instrucciones suministrado con el grupo DIAVIA FRIGO, el cual debe ser consultado por el instalador.
En las páginas siguientes se ilustra una solución alternativa para el montaje del grupo de mando que utiliza la caja personalizada "72A" y que se suministra con esta instalación básica.*

MATERIALE FORNITO / MATERIEL FOURNI / SUPPLIED MATERIAL / GELIEFERTES MATERIAL / MATERIAL ABASTECIDO



Pos.	Descrizione / Description Description / Beschreibung Descripción	Codice / Code Code / Código
72A	Sede comandi personalizzata	0322279/0

Soluzione di montaggio gruppo comandi mediante utilizzo della sede personalizzata "72A"
 Solution de montage du groupe de commandes en utilisant le logement personnalisé "72A"
 Solution for installation of the controls with the customized housing "72A"

Einbaumöglichkeit der Steuerungsgruppe unter Verwendung des persönlich gestalteten Steuerungssitzes "72A"
 Solución para el montaje grupo de mandos utilizando la caja personalizada "72A"

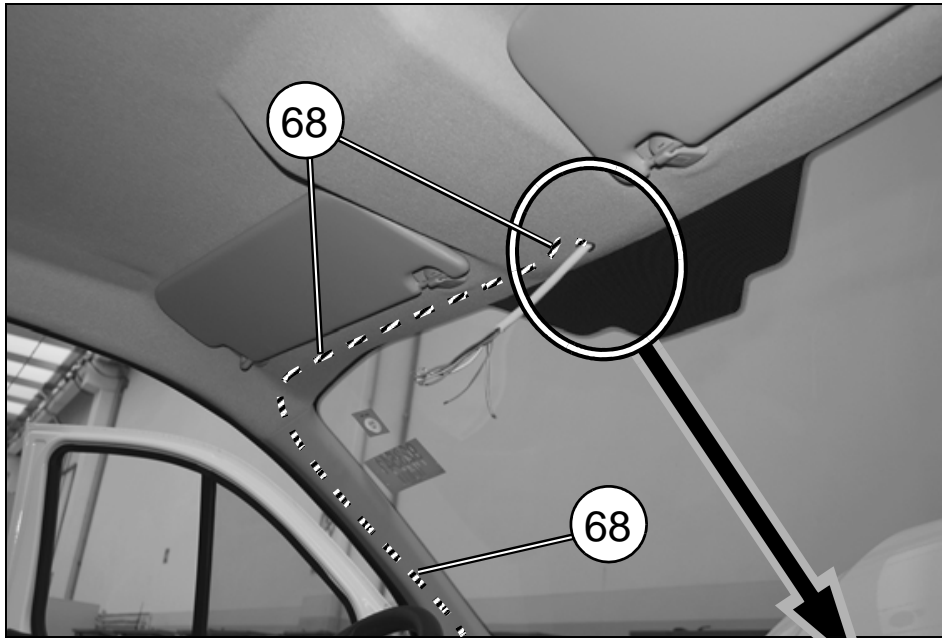

(I)
 Posizionamento impianto elettrico (68) per display.

(F)
 Positionnement du faisceau électrique (68) pour display.

(GB)
 Position of the electric wiring (68) for display.

(D)
 Positionierung der elektrischen Anlage (68) für Display.

(E)
 Colocación instalación eléctrica (68) para display.

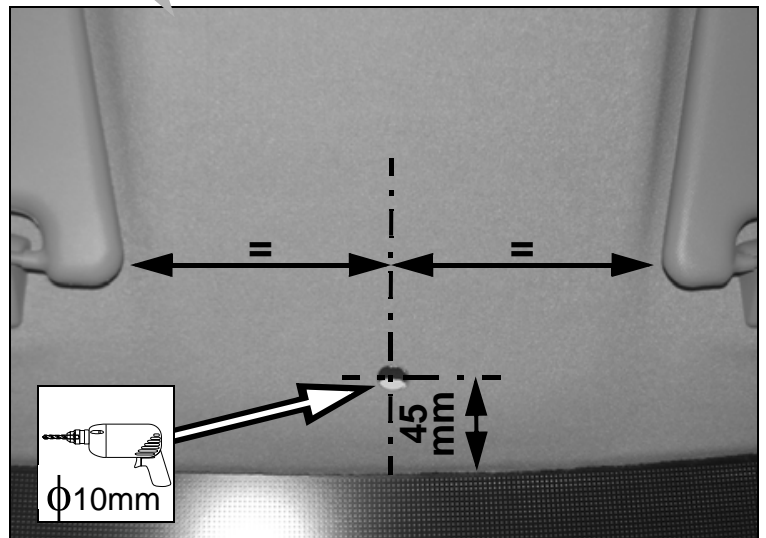

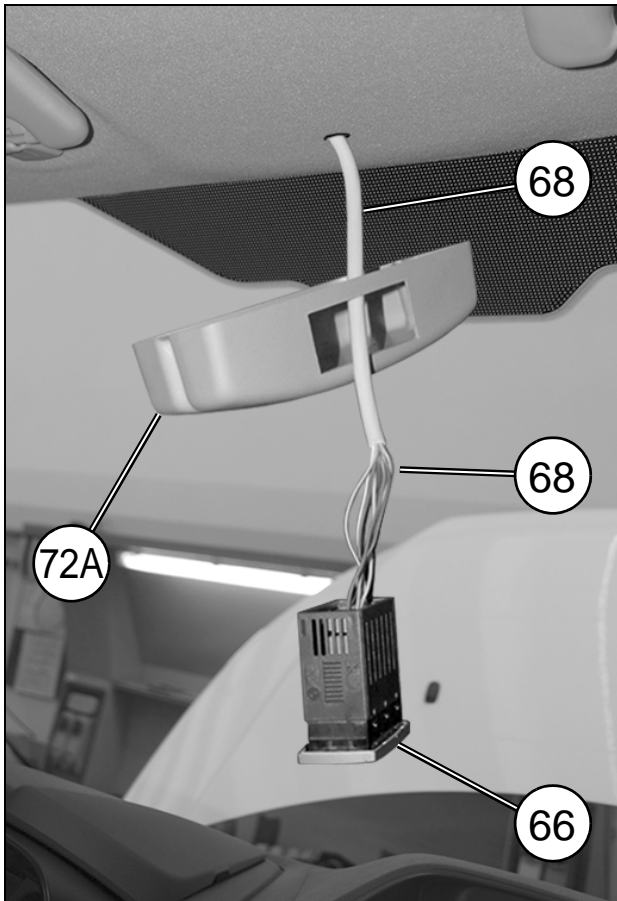

2E

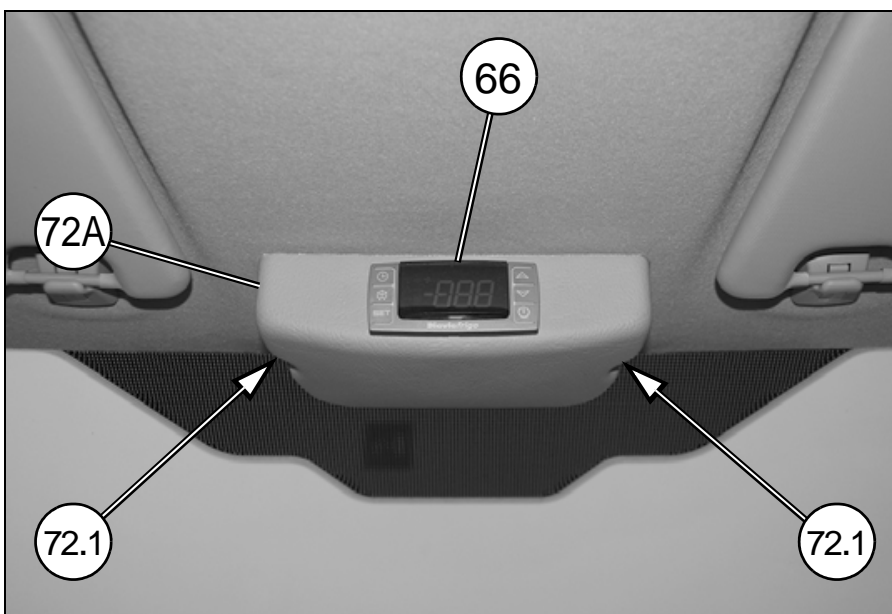
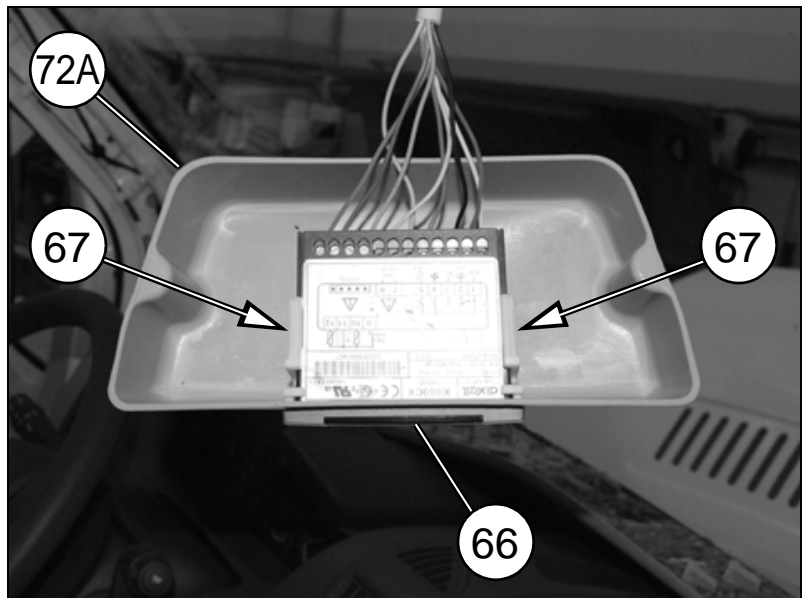

3E



ELEMENTI DI FISSAGGIO PIECES DE FIXATION FIXING PARTS BEFESTIGUNGSELEMENTE ELEMENTOS DE FIJACION		
Pos.	Tipologia Typologie Typology Tipologie Tipologia	Descrizione Description Description Beschreibung Descripción
72.1	 	4 x 14

COLLEGAMENTO TUBI GAS
INSTALLAZIONE IMPIANTO ELETTRICO DIAVIA FRIGO E COMPONENTI ELETTRICI NEL VANO MOTORE
RACCORDEMENT DES TUYAUX GAZ
INSTALLATION FAISCEAU ELECTRIQUE DIAVIA FRIGO ET COMPOSANTS ELECTRIQUES DANS LE COMPARTIMENT MOTEUR
GAS HOSES CONNECTION
DIAVIA FRIGO ELECTRIC SYSTEM AND ELECTRIC COMPONENTS INSTALLATION IN THE ENGINE COMPARTMENT
ANSCHLUSS DER KÄLTEMITTELSCHLÄUCHE
EINBAU DER DIAVIA FRIGO-ELEKTROANLAGE UND DER ELEKTROBESTANDTEILE IM MOTORRAUM
CONEXIÓN DE LOS TUBOS DEL GAS
INSTALACIÓN ELÉCTRICA DIAVIA FRIGO Y LOS COMPONENTES ELÉCTRICOS EN EL COMPARTIMENTO DEL MOTOR

MATERIALE FORNITO / MATERIEL FOURNI / SUPPLIED MATERIAL / GELIEFERTES MATERIAL / MATERIAL ABASTECIDO

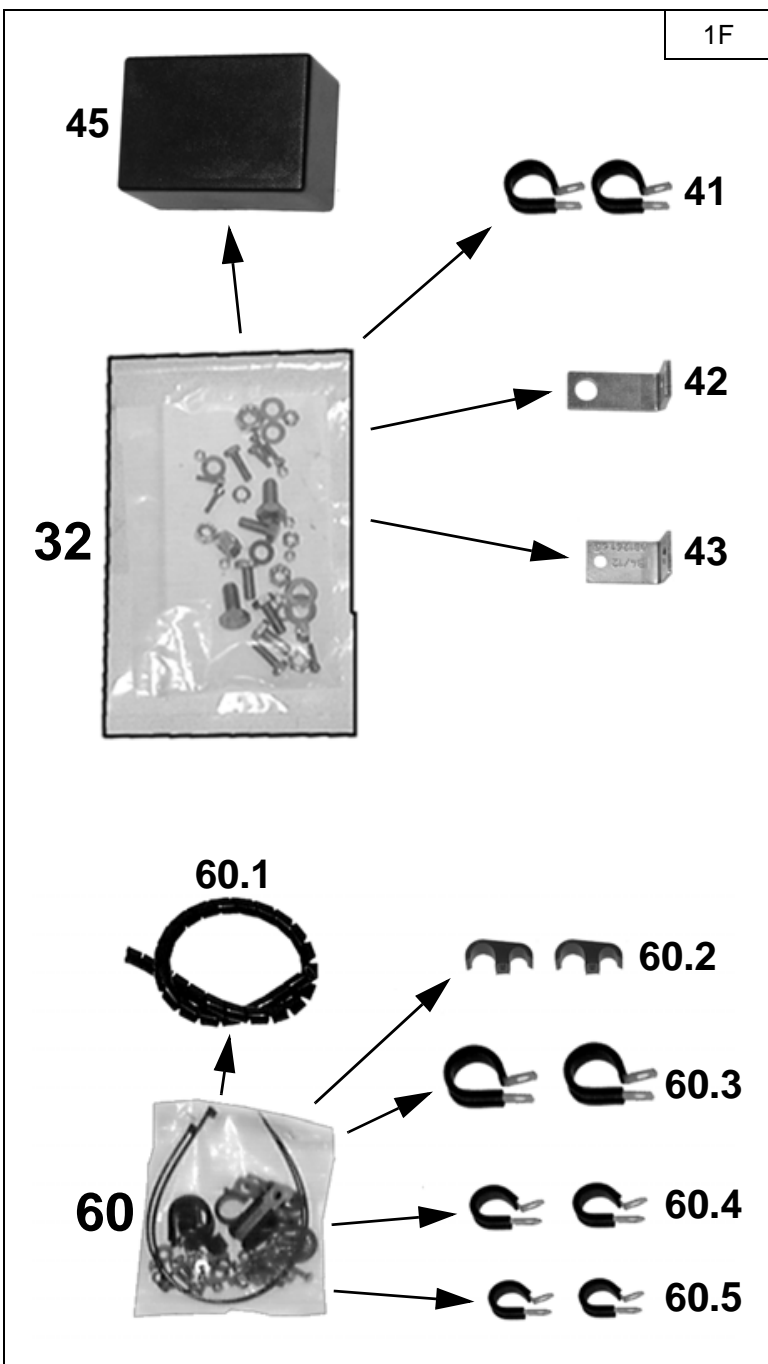

Pos.	Descrizione / Description Description / Beschreibung Descripción	Codice Code / Kode Codigo
32	Sacchetto accessori	0232171/0
41	Fascetta in gomma	069201/1
42	Staffa	0811077/0
43	Staffa	081261.6
45	Protezione relay	0361158/0
60	Sacchetto fissaggio tubi gas	0231621/0
60.1	Protezione a spirale	0701486/0
60.2	Fascetta fissatubo a 2 vie	069177/0
60.3	Fascetta in gomma	069241/1
60.4	Fascetta in gomma	069033/0
60.5	Fascetta in gomma	069032/0

MATERIALE FORNITO / MATERIEL FOURNI / SUPPLIED MATERIAL / GELIEFERTES MATERIAL / MATERIAL ABASTECIDO

0282565/0

2F

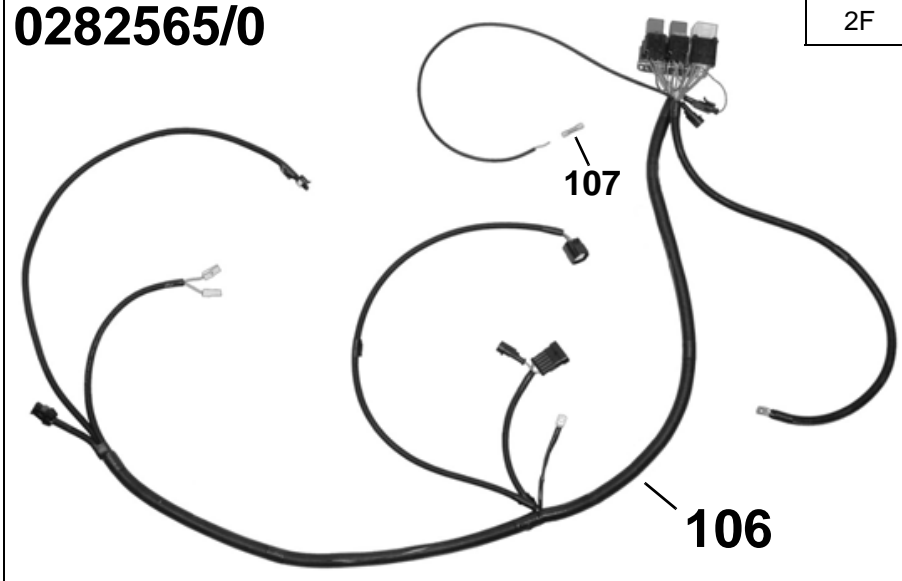

Pos.	Descrizione / Description Description / Beschreibung Descripción	Codice Code / Kode Codigo
106	Impianto elettrico Elettroventole	0282565/0
107	Giunzione RAYCHEM BLU	064273/0

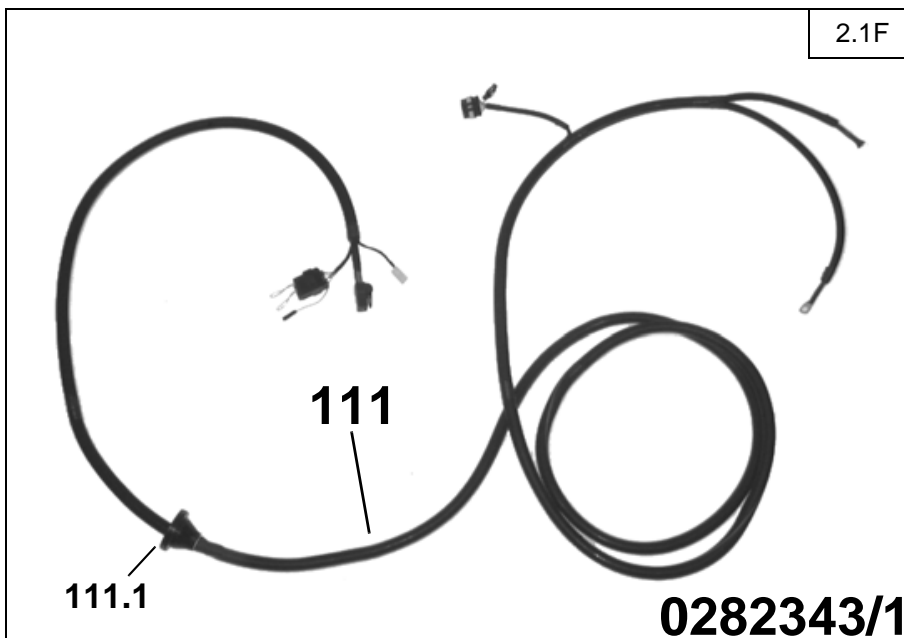

2.1F

Pos.	Descrizione Description / Description Beschreibung / Descripción	Codice Code / Kode Codigo
111	Impianto elettrico intermedio	0282343/1
111.1	Gommino passacavi	069109/0

0282343/1

MATERIALE FORNITO / MATERIEL FOURNI / SUPPLIED MATERIAL / GELIEFERTES MATERIAL / MATERIAL ABASTECIDO

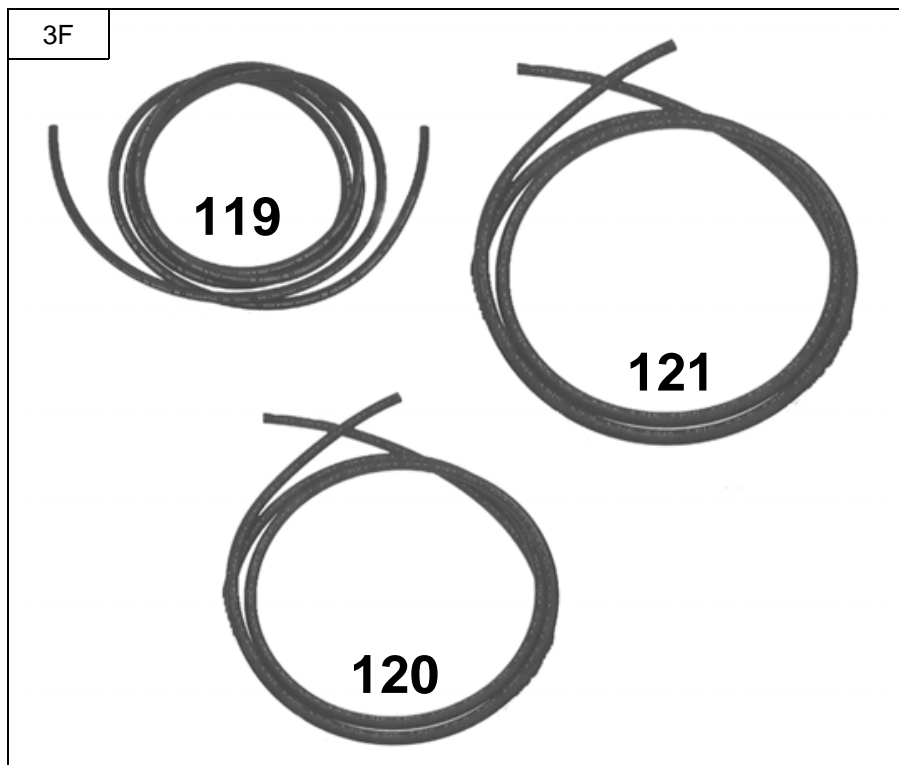

Pos.	Descrizione / Description Description / Beschreibung Descripción	Codice Code / Kode Codigo
54	Sacchetto accessori per separatore olio	0231654/0
118	Sacchetto raccordi	0232170/0
119	Tubo gas 5/16"	90006G2GRFR.1
120	Tubo gas 13/32"	90008G2GRFR.7
121	Tubo gas 1/2"	90010G2GRFR.1
122	Fascetta per raccordi tubi gas 5/16"	0361778/0
123	Fascetta per raccordi tubi gas 13/32"	0361779/0
124	Fascetta per raccordi tubi gas 1/2"	0361780/0
125★	Raccordo tubo gas 5/16"	80106FS002/1
126	Raccordo tubo gas 5/16"	80106FS007
127	Raccordo tubo gas 5/16"	80106FS033
128	Raccordo tubo gas 5/16"	80106FS005/1
129	Raccordo tubo gas 5/16"	80106FS004/1
130★	Raccordo tubo gas 13/32"	80108FS003/1
131	Raccordo tubo gas 13/32"	80108FS009
132	Raccordo tubo gas 13/32"	80108FS010
133	Raccordo tubo gas 1/2"	80110FS024
134	Raccordo tubo gas 1/2"	80110FS010
135	Raccordo tubo gas 1/2"	80110FS028
136	Raccordo tubo gas 1/2"	80110FS005
★	Da non utilizzare nella presente installazione A ne pas utiliser dans cette installation Not to be used in this installation Nicht folgeden Einbau zu verwenden No hay que usar en la presente instalación	

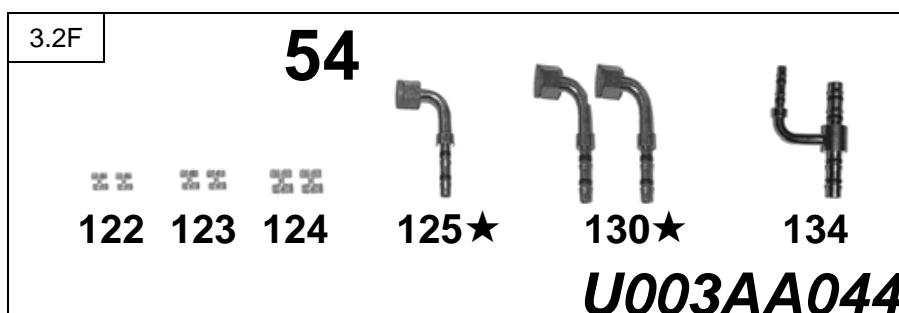
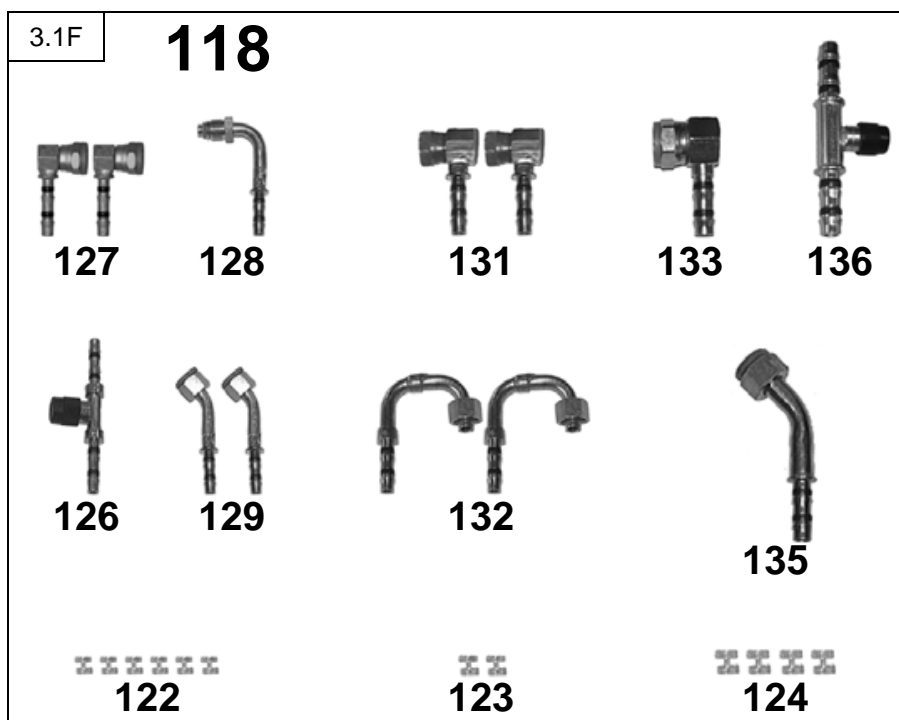

SCHEMA COLLEGAMENTO TUBI GAS E CIRCOLAZIONE FLUIDO REFRIGERANTE
 SCHEMA CONNEXION TUYAUX GAZ ET CIRCULATION FLUIDE REFRIGERANT
 DIAGRAM OF GAS AND REFRIGERANT CIRCULATION HOSE CONNECTIONS
 VERBINDUNGSSCHEMA DER KÄLTEMITTELSCHLÄUCHE UND DES KÜHLMITTELUMLAUF
 ESQUEMA CONEXIÓN TUBOS GAS Y CIRCULACIÓN FLUIDO REFRIGERANTE

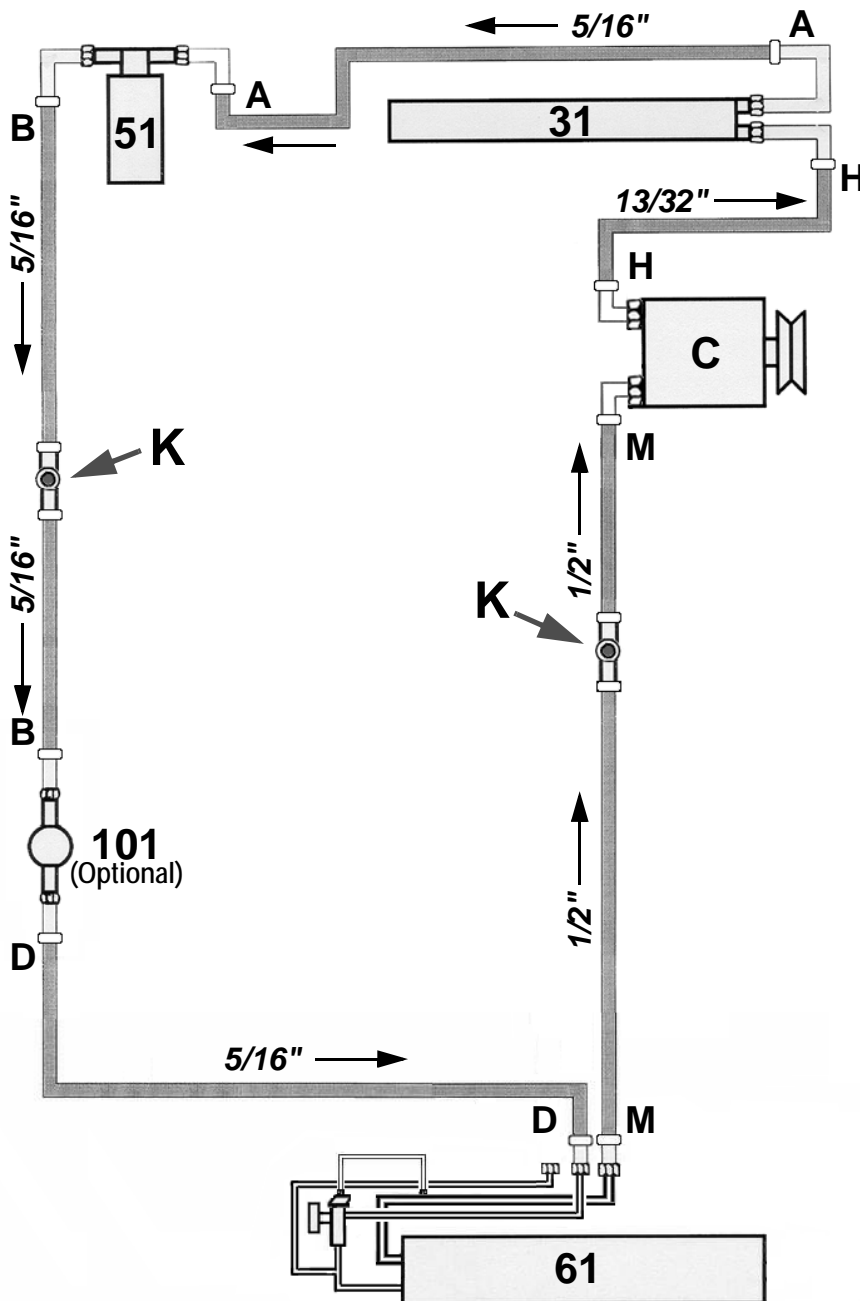

C	Compressore
31	Condensatore
51	Filtro essiccatore
61	Gruppo refrigerante
101	Indicatore passaggio liquido e umidità (Optional Kit)

A	Tubo gas 5/16"
B	Tubo gas 5/16"
D	Tubo gas 5/16"
H	Tubo gas 13/32"
M	Tubo gas 1/2"
K	Raccordo con punto di carica

4F

R134a

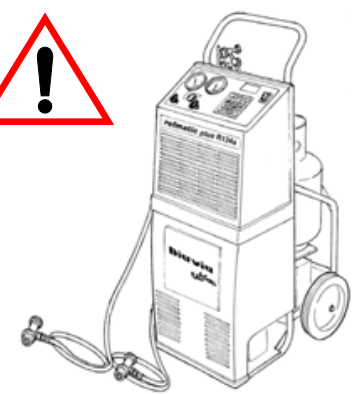

Kg.1,500 (±0,025)

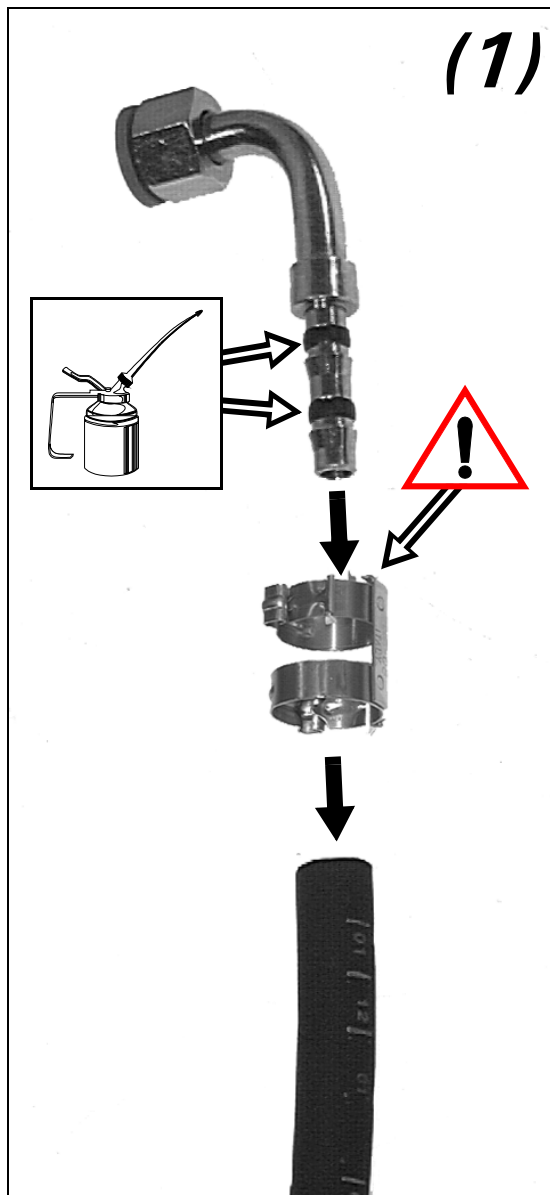

(1)

(I) PROCEDURA PER IL BLOCCAGGIO DI TUTTI I TUBI GAS AI RACCORDI

(1) Oliare O.R.; innestare raccordo nel tubo alloggiando la fascetta con la linguetta di battuta nella posizione di figura (2); bloccare con apposita pinza la fascetta nei due punti (3).

(F) PROCEDURE POUR LA FIXATION DE TOUS LES TUYAUX GAZ AUX RACCORDS

(1) Huiler O.R.; emboîter le raccord dans le tuyau et loger le collier avec la languette de contact comme indiqué sur la figure (2); fixer à l'aide de la pince appropriée aux deux points (3).

(GB) PROCEDURE FOR LOCKING ALL GAS HOSES TO THE CONNECTIONS

(1) Oil the O-ring; snap the connection into the hose, positioning the clamp with the tab flush in the position indicated in the figure (2); lock the clamp in place at two points using the special pliers (3).

5F

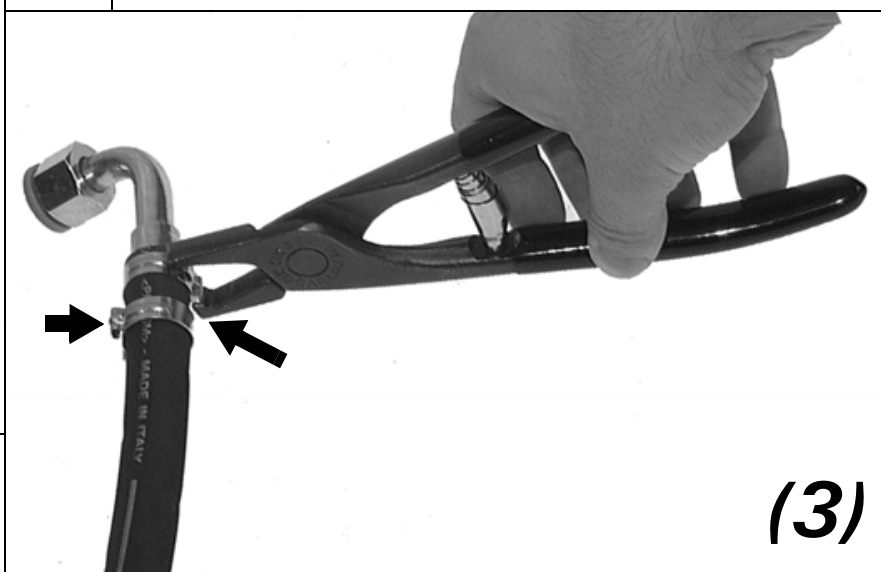

(3)

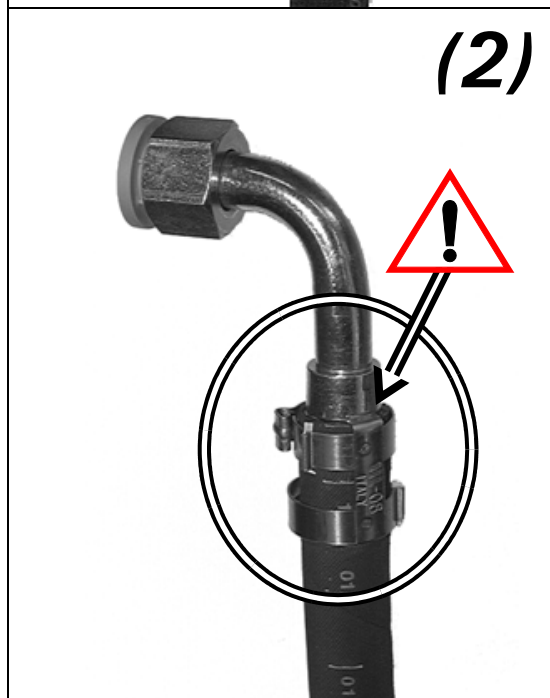

(2)

(D) BLOCKIERUNGSVERFAHREN ALLER KÜHLMITTELSCHLÄUCHE AN DEN VERBINDUNGSSTÜCKEN

(1) O.R. Ring ölen: Verbindungsstück an Schlauch ankuppeln und die Schelle mit dem Anschlag des Betätigungshebels in gezeigter Position anbringen (2): mit entsprechender Zange die Schelle in den beiden Punkten festziehen (3).

(E) PROCEDIMIENTO PARA LA FIJACIÓN DE TODOS LOS TUBOS A LOS RACORES

(1) Lubricar O.R., insertar el racor en el tubo colocando la banda con la lengüeta de golpe en la posición de figura (2); bloquear la banda en los dos puntos con pinza apropiada (3).

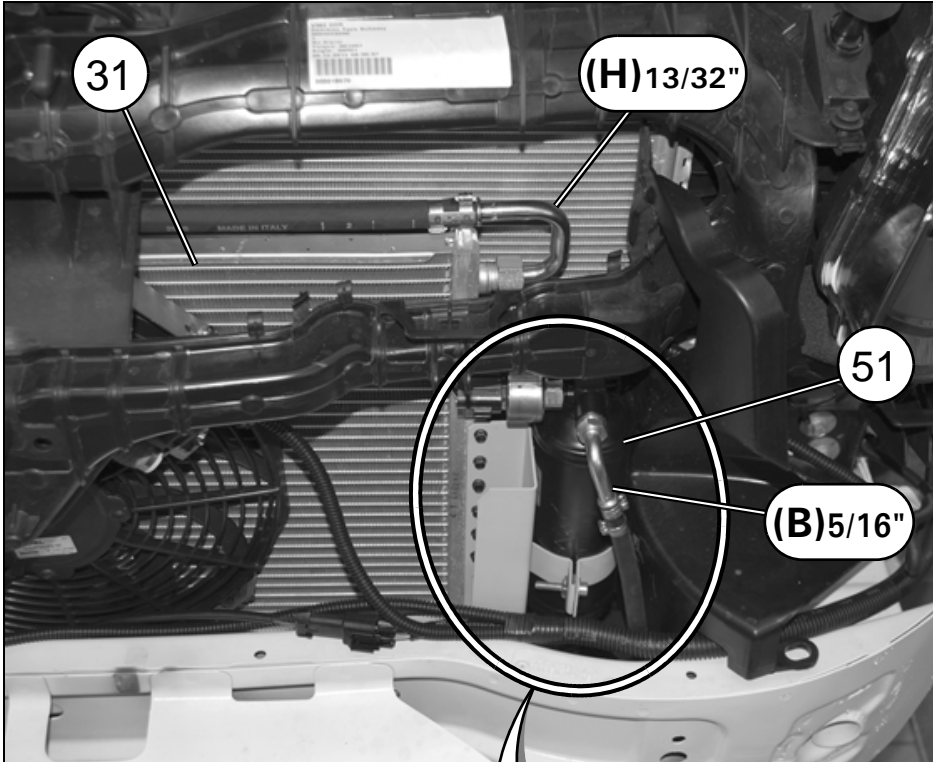

6F

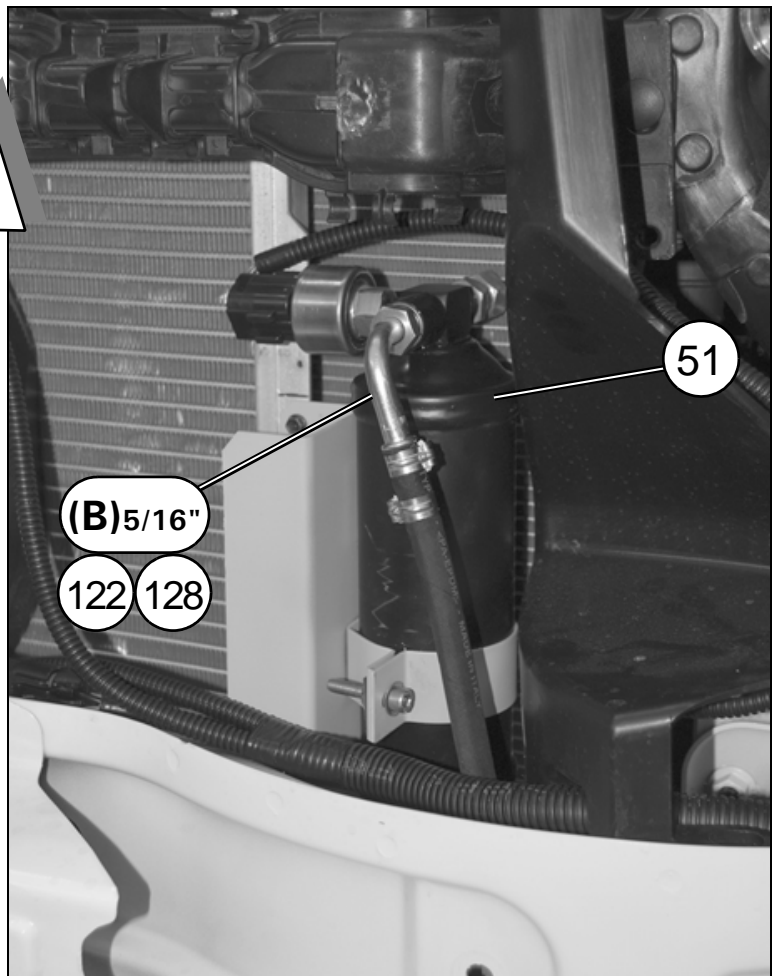

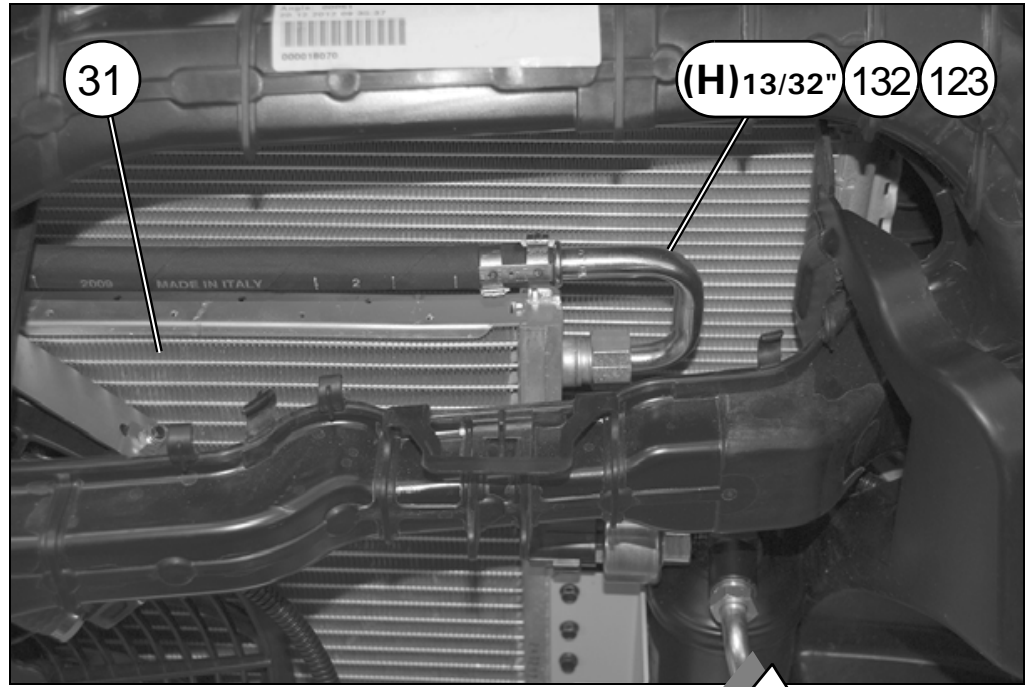

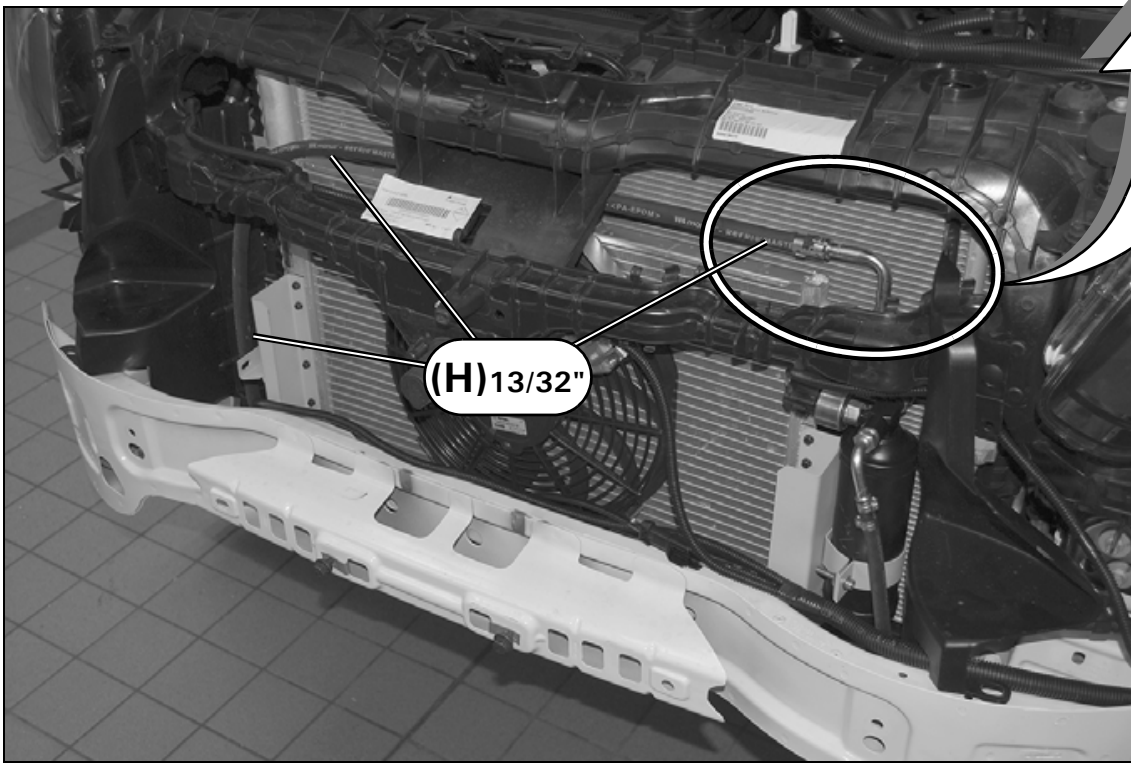

7F

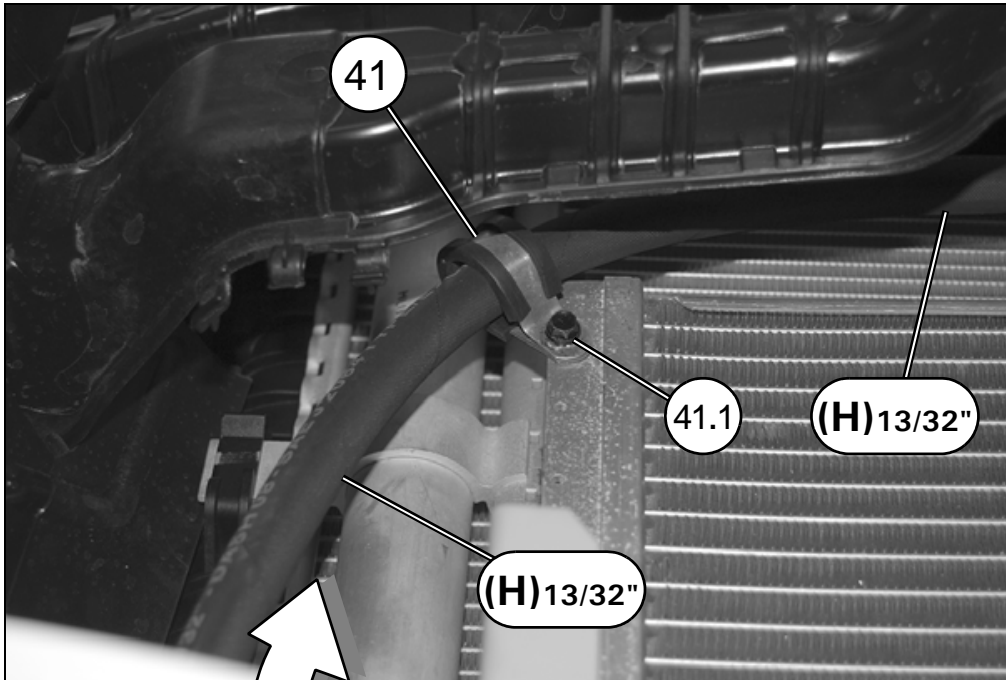

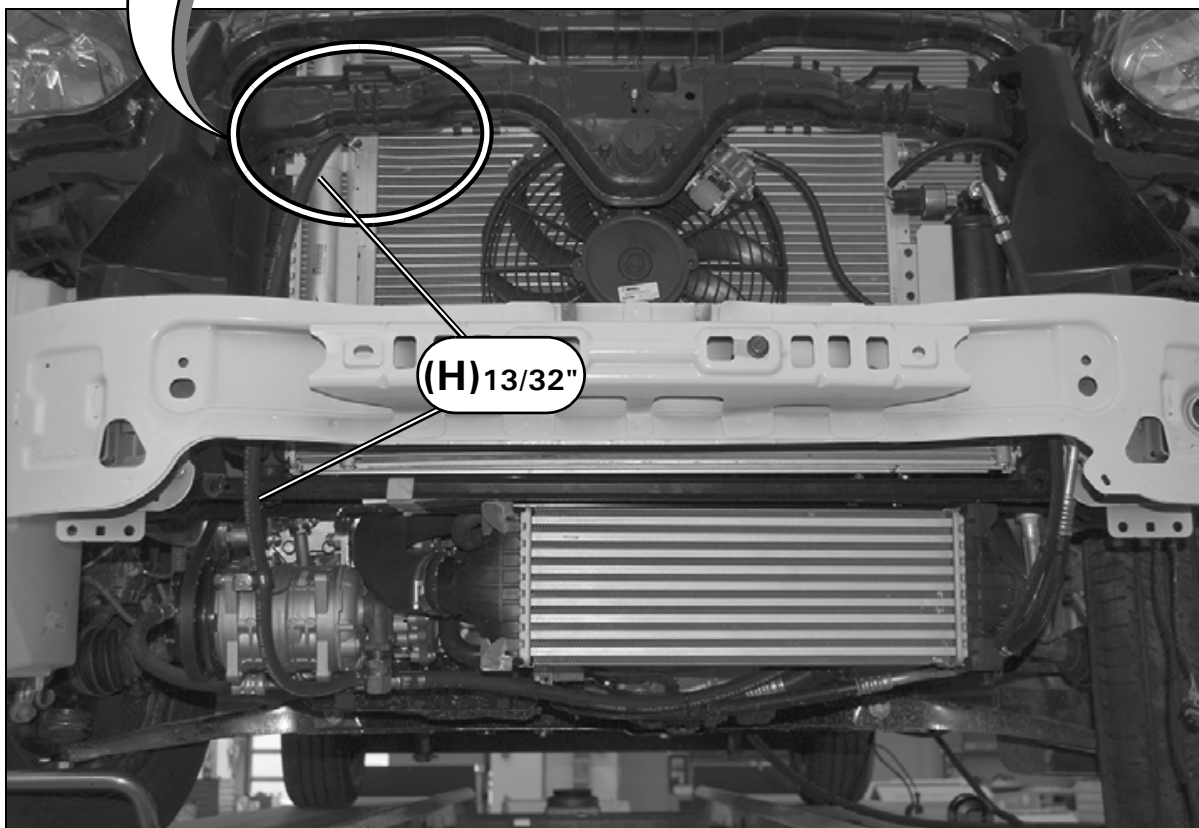

8F



ELEMENTI DI FISSAGGIO / PIECES DE FIXATION / FIXING PARTS BEFESTIGUNGSELEMENTE / ELEMENTOS DE FIJACION		
Pos.	Tipologia / Typologi Typology / Tipologie Tipologia	Descrizione / Description Description / Beschreibung Descripción
41.1		4,2 x 13

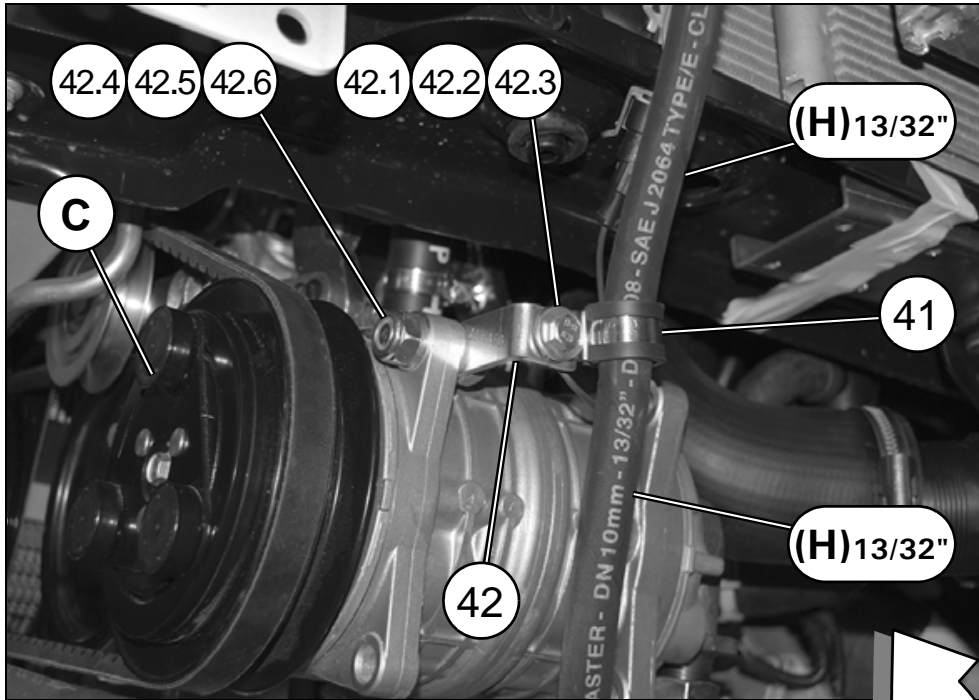

9F

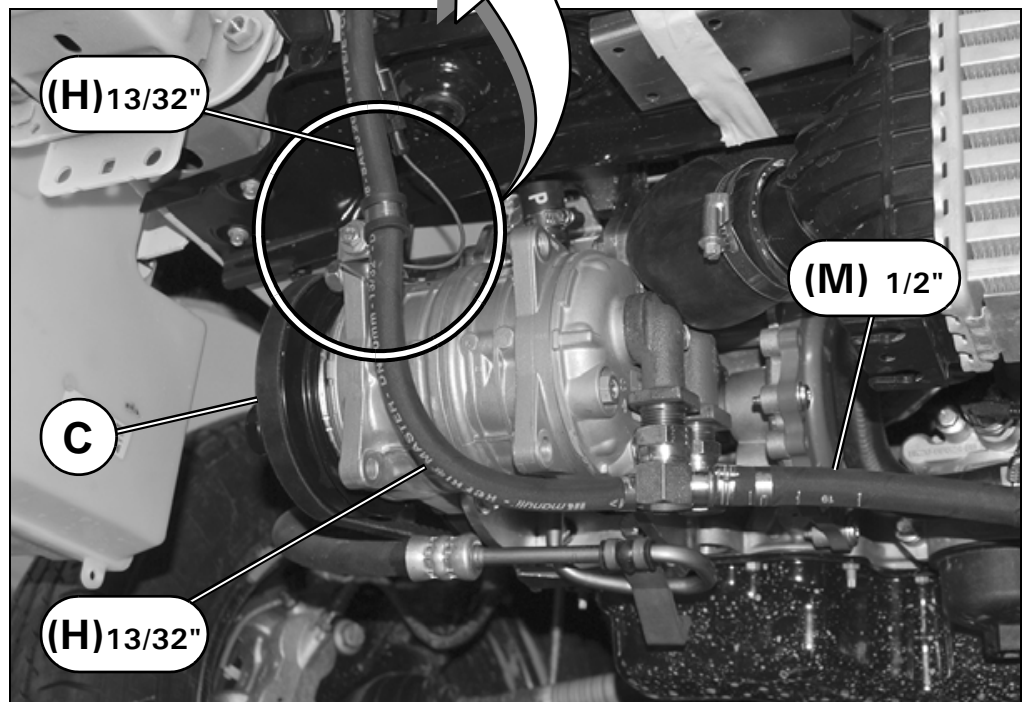

ELEMENTI DI FISSAGGIO / PIECES DE FIXATION FIXING PARTS / BEFESTIGUNGSELEMENTE ELEMENTOS DE FIJACION		
Pos.	Tipologia / Typologi Typology / Tipologie Tipologia	Descrizione / Description Description / Beschreibung Descripción
42.1		M6x16
42.2		φ6xφ18x2
42.3		M6

ELEMENTI DI FISSAGGIO / PIECES DE FIXATION FIXING PARTS / BEFESTIGUNGSELEMENTE ELEMENTOS DE FIJACION		
Pos.	Tipologia / Typologi Typology / Tipologie Tipologia	Descrizione / Description Description / Beschreibung Descripción
42.4		M10x30
42.5		φ 10
42.6		M10

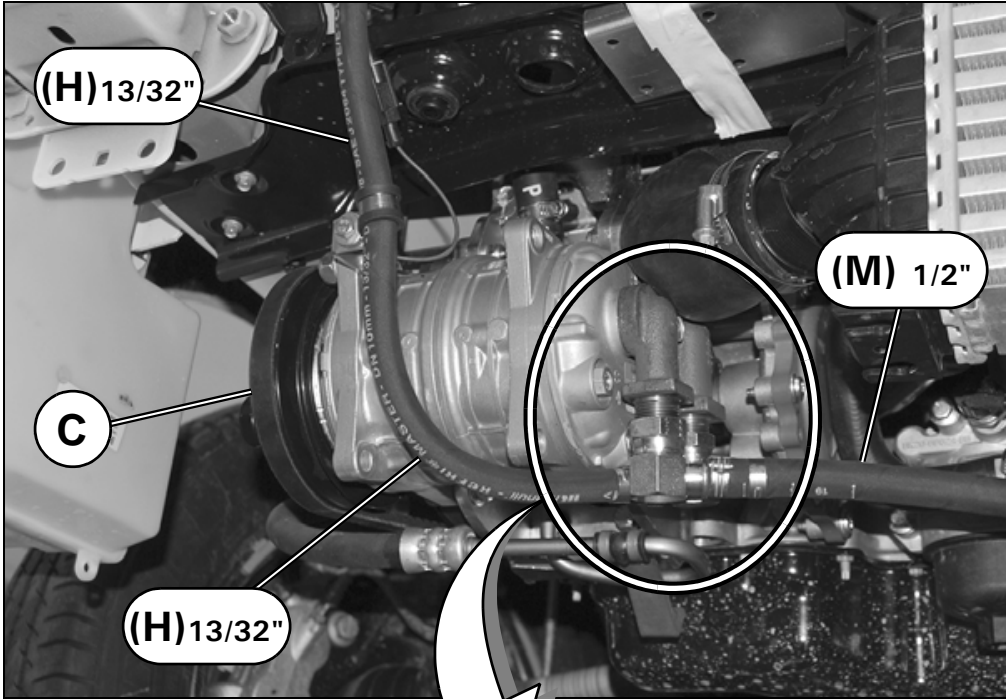

10F

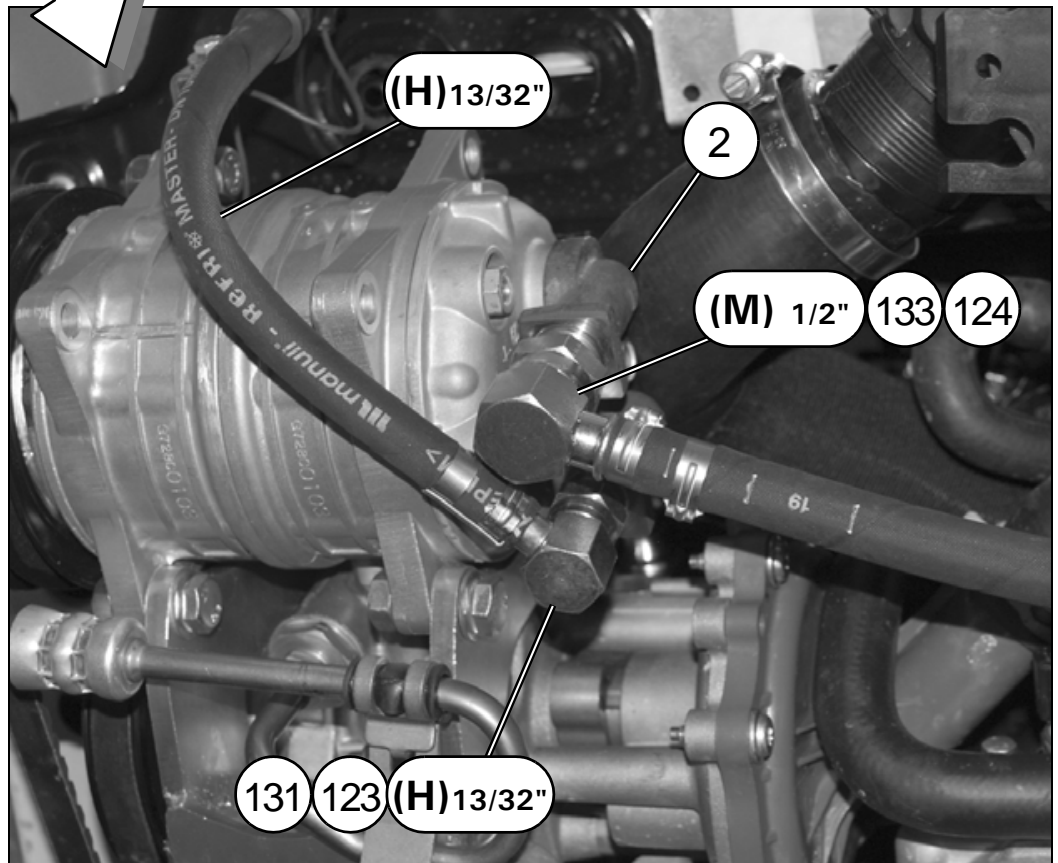

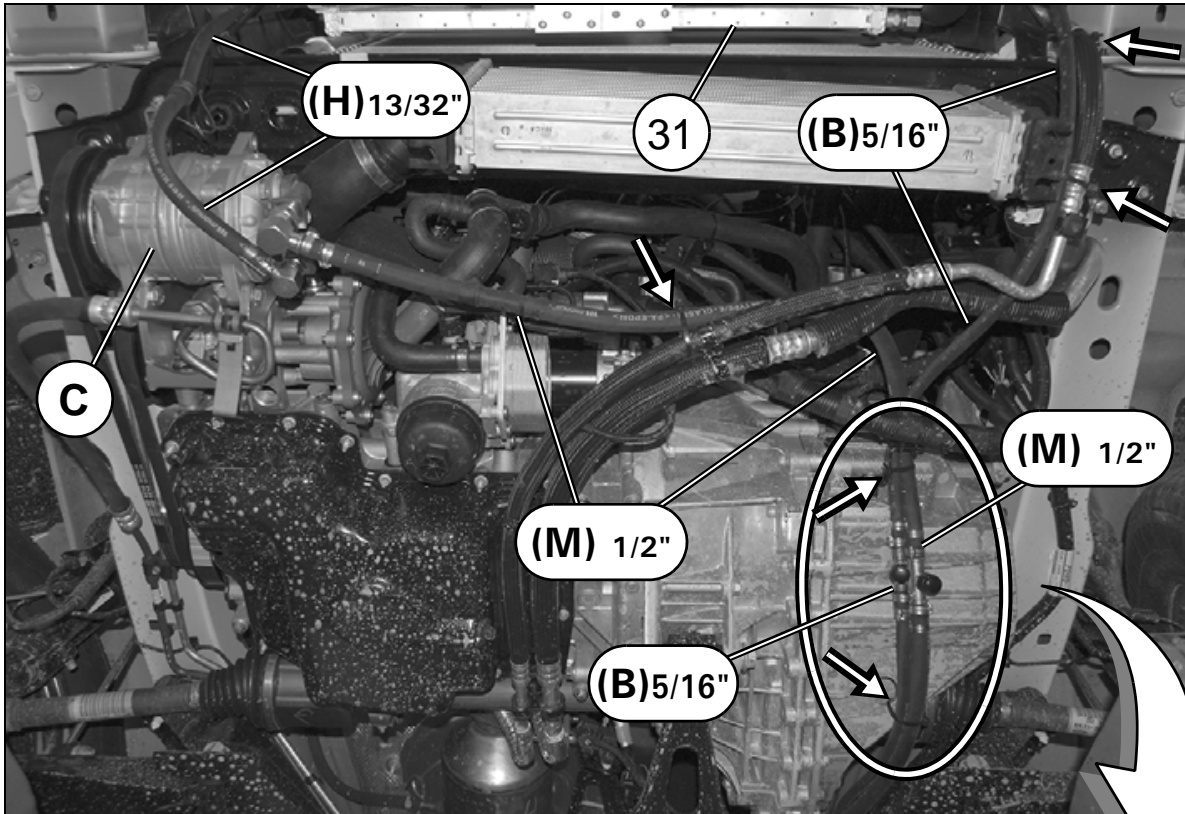

11F

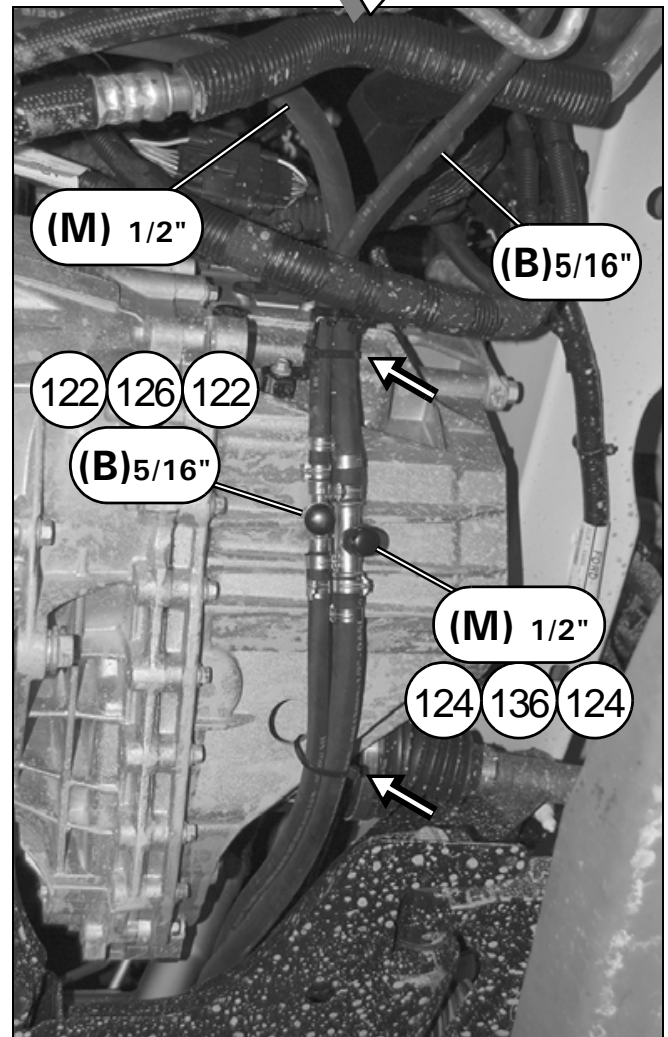

ELEMENTI DI FISSAGGIO / PIÈCES DE FIXATION FIXING PARTS / BEFESTIGUNGSELEMENTE ELEMENTOS DE FIJACION		
Pos.	Tipologia / Typologie Typology / Tipologie Tipologia	Descrizione / Description Description / Beschreibung Descripción
		Fascetta a strappo

SCHEMA COLLEGAMENTO TUBI GAS E CIRCOLAZIONE FLUIDO REFRIGERANTE
 SCHEMA CONNEXION TUYAUX GAZ ET CIRCULATION FLUIDE REFRIGERANT
 DIAGRAM OF GAS AND REFRIGERANT CIRCULATION HOSE CONNECTIONS
 VERBINDUNGSSCHEMA DER KÄLTEMITTELSCHLÄUCHE UND DES KÜHLMITTELUMLAUFS
 ESQUEMA CONEXIÓN TUBOS GAS Y CIRCULACIÓN FLUIDO REFRIGERANTE

+ OPTIONAL KIT

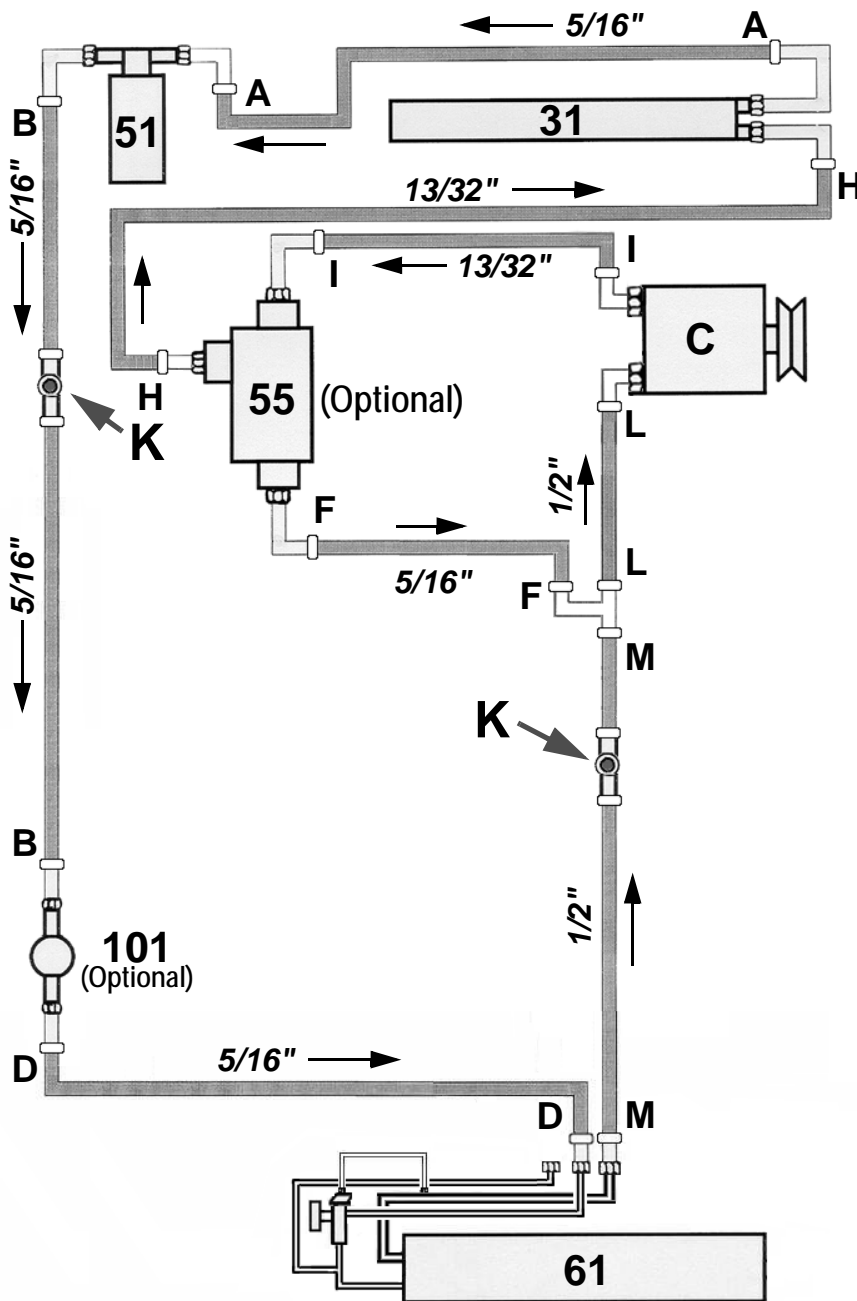

C	Compressore
31	Condensatore
51	Filtro essiccatore
55	Separatore olio (Optional Kit)
61	Gruppo refrigerante
101	Indicatore passaggio liquido e umidità (Optional Kit)

A	Tubo gas 5/16"
B	Tubo gas 5/16"
D	Tubo gas 5/16"
F	Tubo gas 5/16"
H	Tubo gas 13/32"
I	Tubo gas 13/32"
L	Tubo gas 1/2"
M	Tubo gas 1/2"
K	Raccordo con punto di carica

12F

R134a



Kg. 1,500 (±0,025)

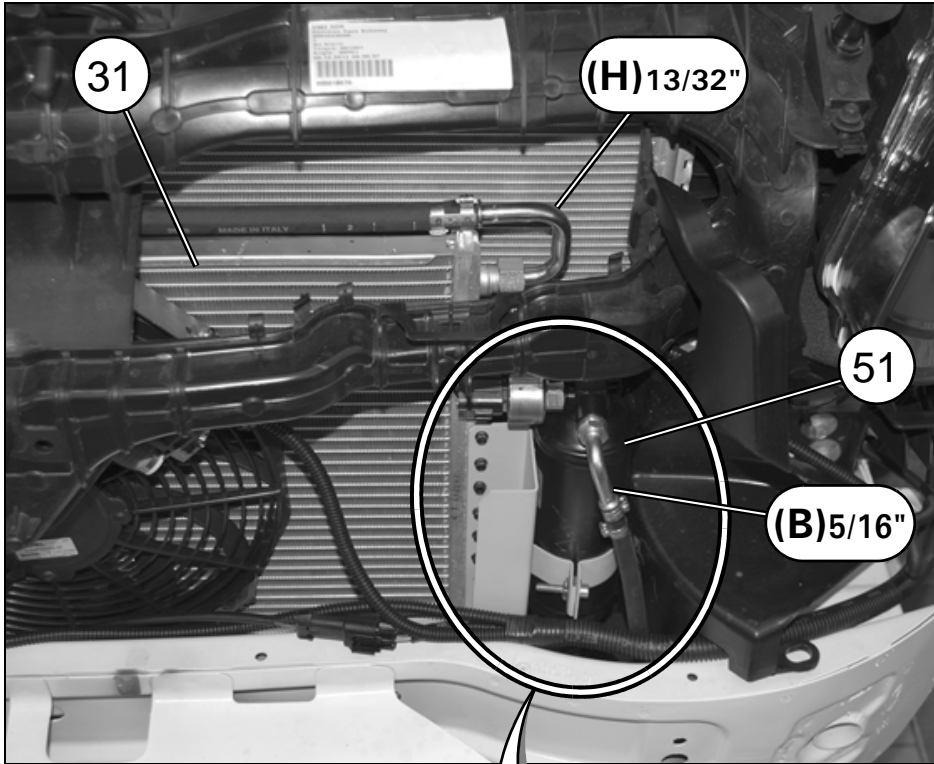

+ OPTIONAL KIT

13F

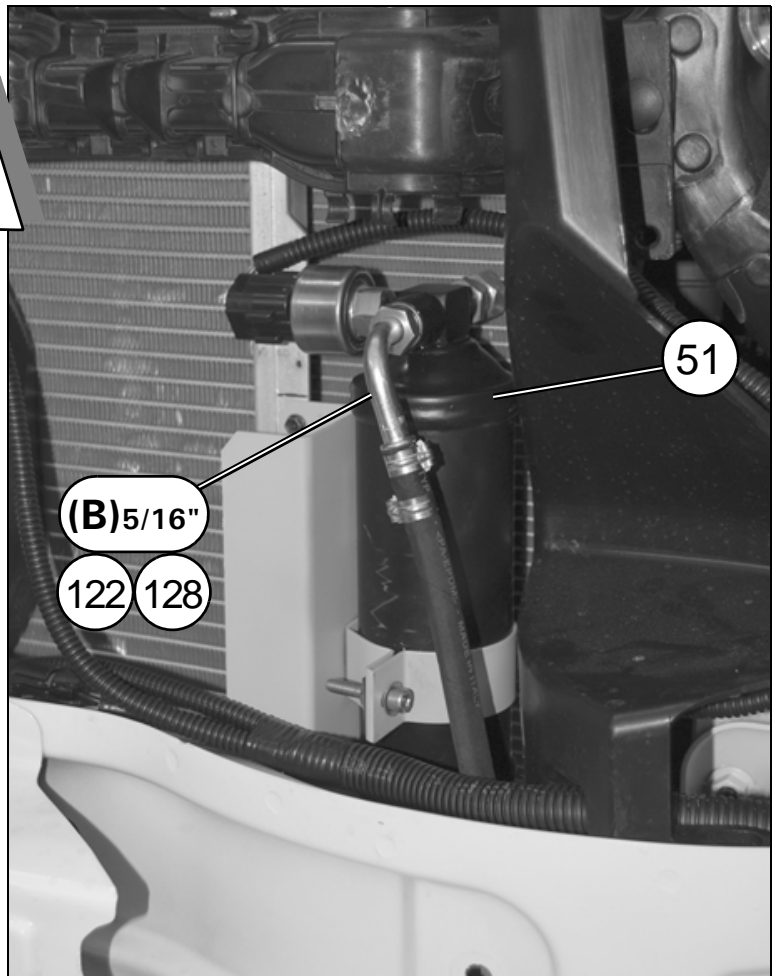

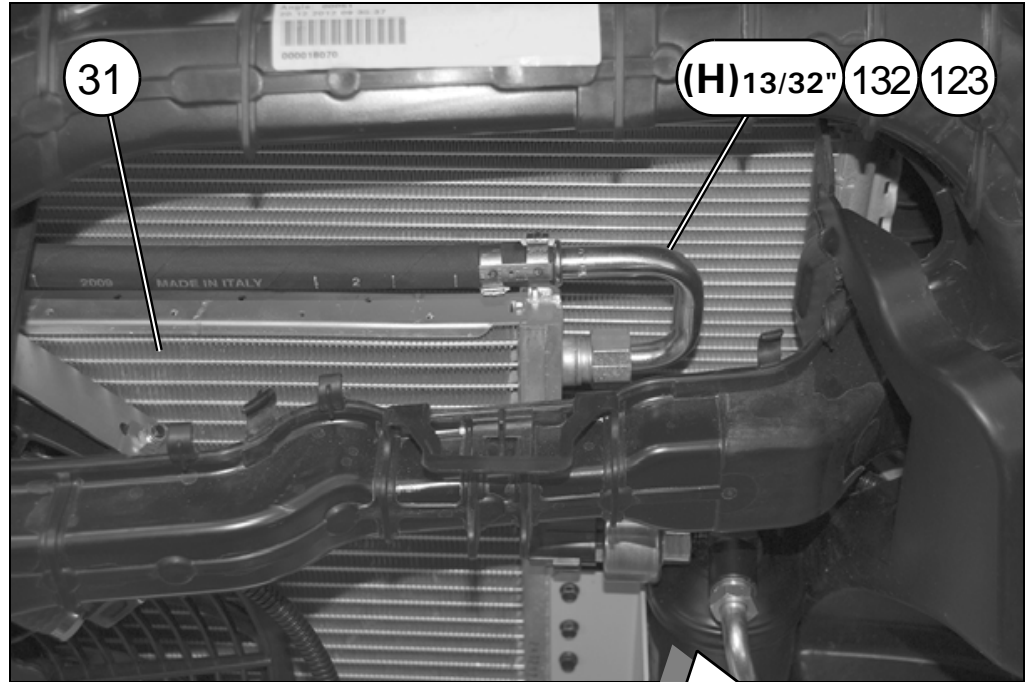

+ OPTIONAL KIT

14F

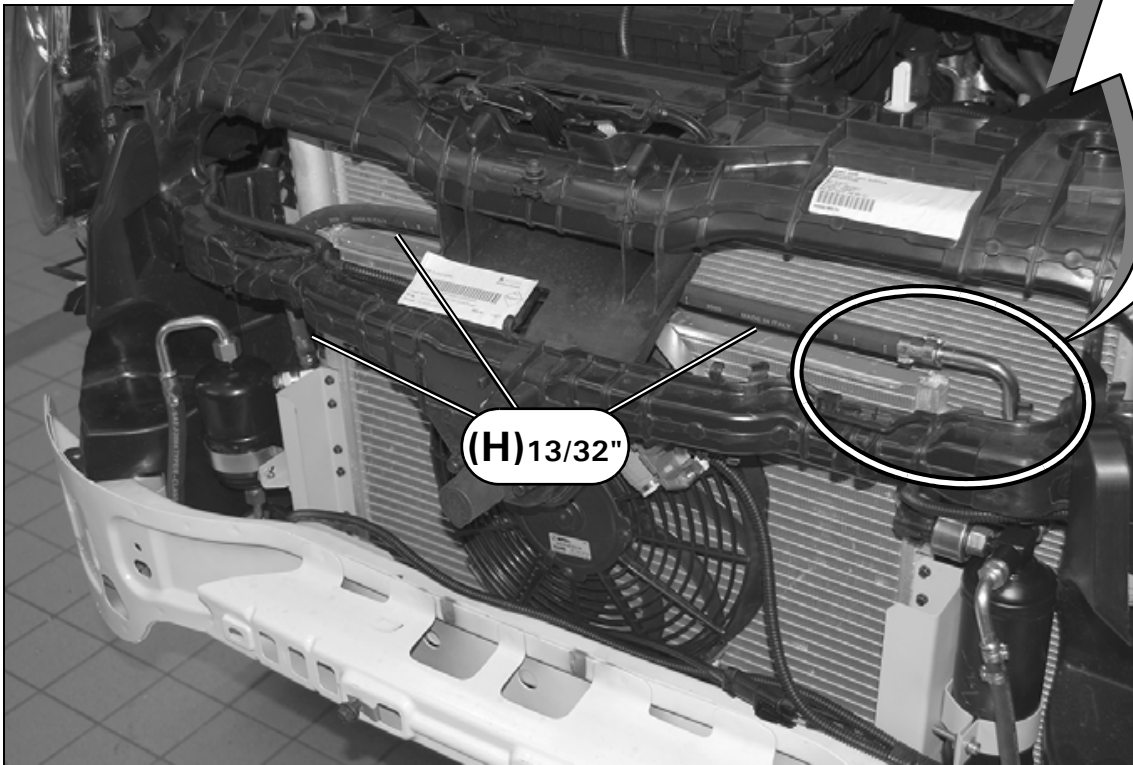

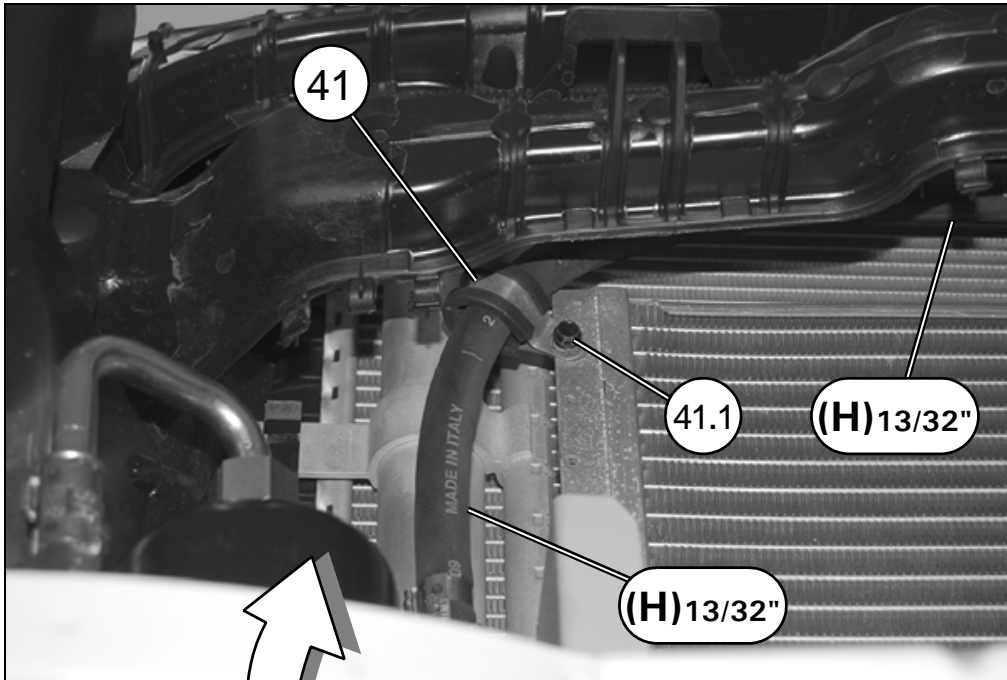

+ OPTIONAL KIT

15F

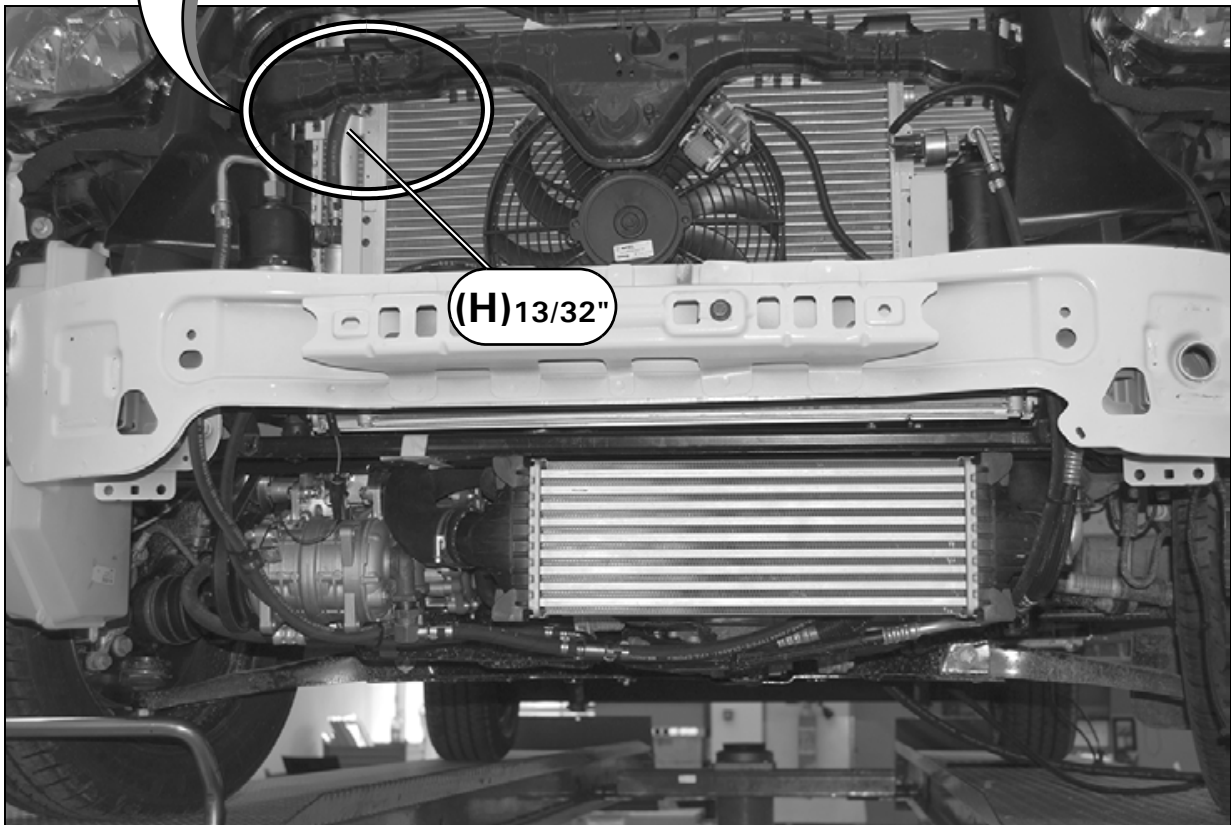

ELEMENTI DI FISSAGGIO / PIECES DE FIXATION / FIXING PARTS BEFESTIGUNGSELEMENTE / ELEMENTOS DE FIJACION		
Pos.	Tipologia / Typologi Typology / Tipologie Tipologia	Descrizione / Description Description / Beschreibung Descripción
41.1		4,2 x 13

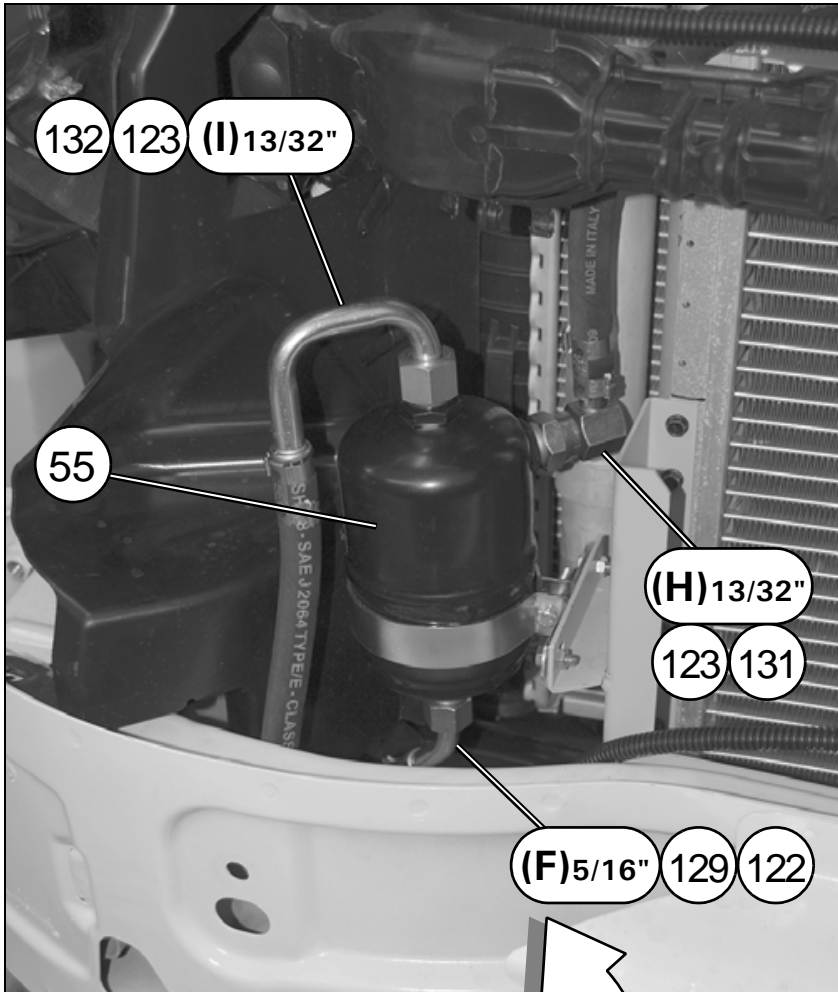

+ OPTIONAL KIT

16F

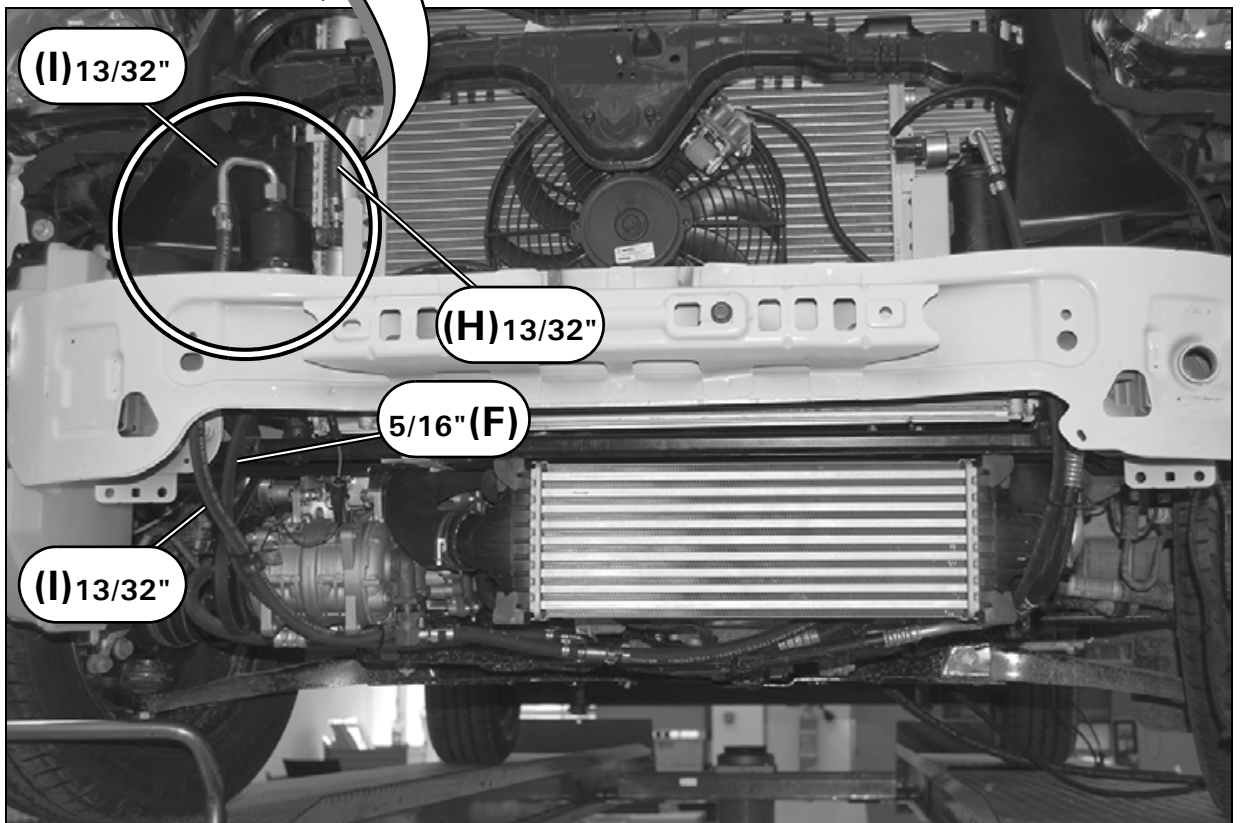

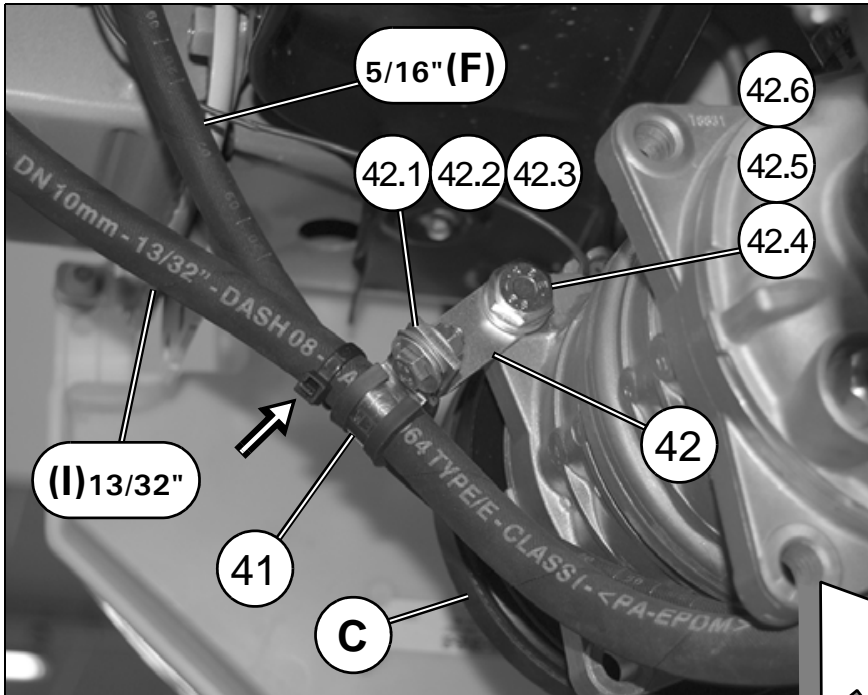

ELEMENTI DI FISSAGGIO / PIECES DE FIXATION
FIXING PARTS / BEFESTIGUNGSELEMENTE
ELEMENTOS DE FIJACION

Pos.	Tipologia Typology Typologie Tipologie Tipologia	Descrizione Description Description Beschreibung Descripción
		Fascetta a strappo

+ OPTIONAL KIT

17F

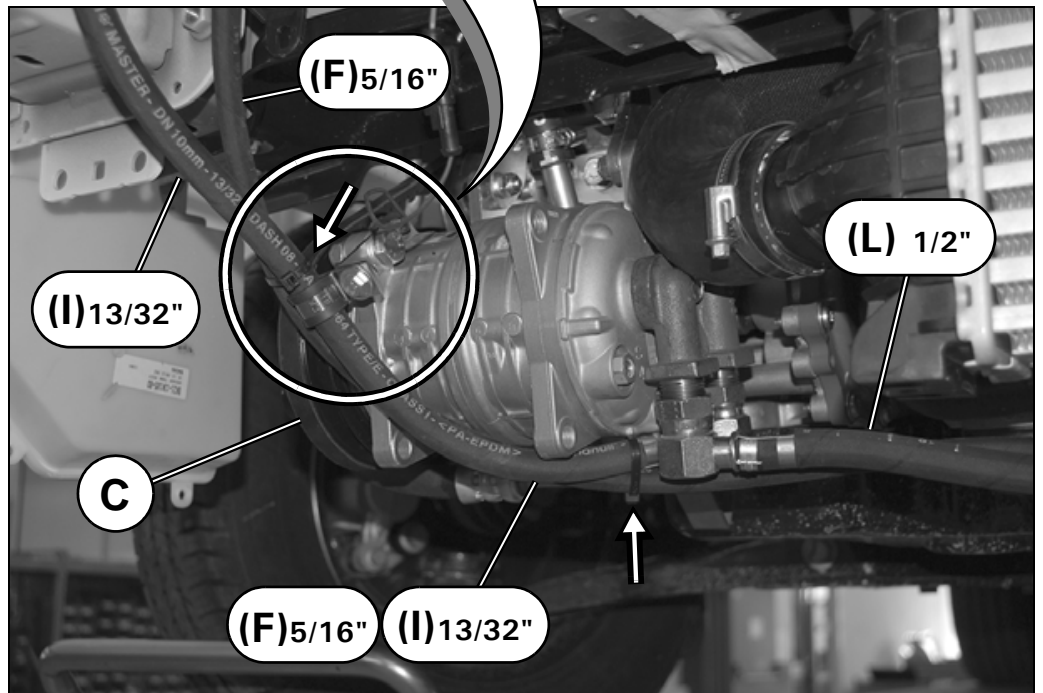

ELEMENTI DI FISSAGGIO / PIECES DE FIXATION
FIXING PARTS / BEFESTIGUNGSELEMENTE
ELEMENTOS DE FIJACION

Pos.	Tipologia / Typologi Typology / Tipologie Tipologia	Descrizione / Description Description / Beschreibung Descripción
42.1		M6x16
42.2		φ6xφ18x2
42.3		M6

ELEMENTI DI FISSAGGIO / PIECES DE FIXATION
FIXING PARTS / BEFESTIGUNGSELEMENTE
ELEMENTOS DE FIJACION

Pos.	Tipologia / Typologi Typology / Tipologie Tipologia	Descrizione / Description Description / Beschreibung Descripción
42.4		M10x30
42.5		φ 10
42.6		M10

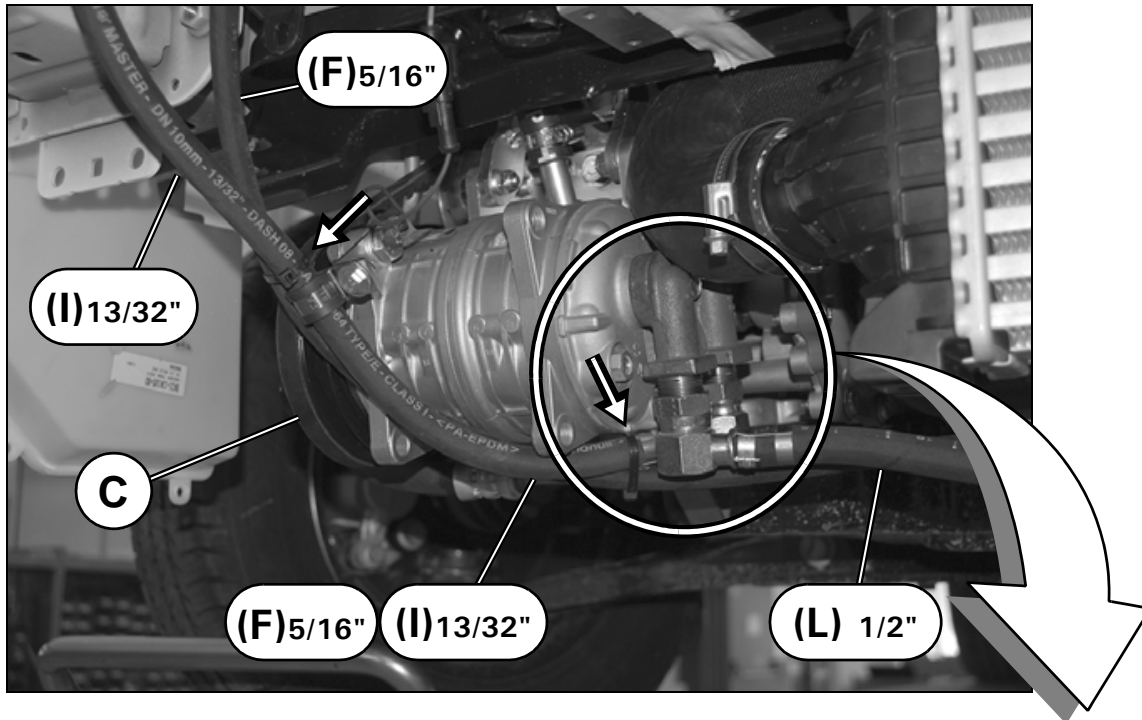

18F

+ OPTIONAL KIT

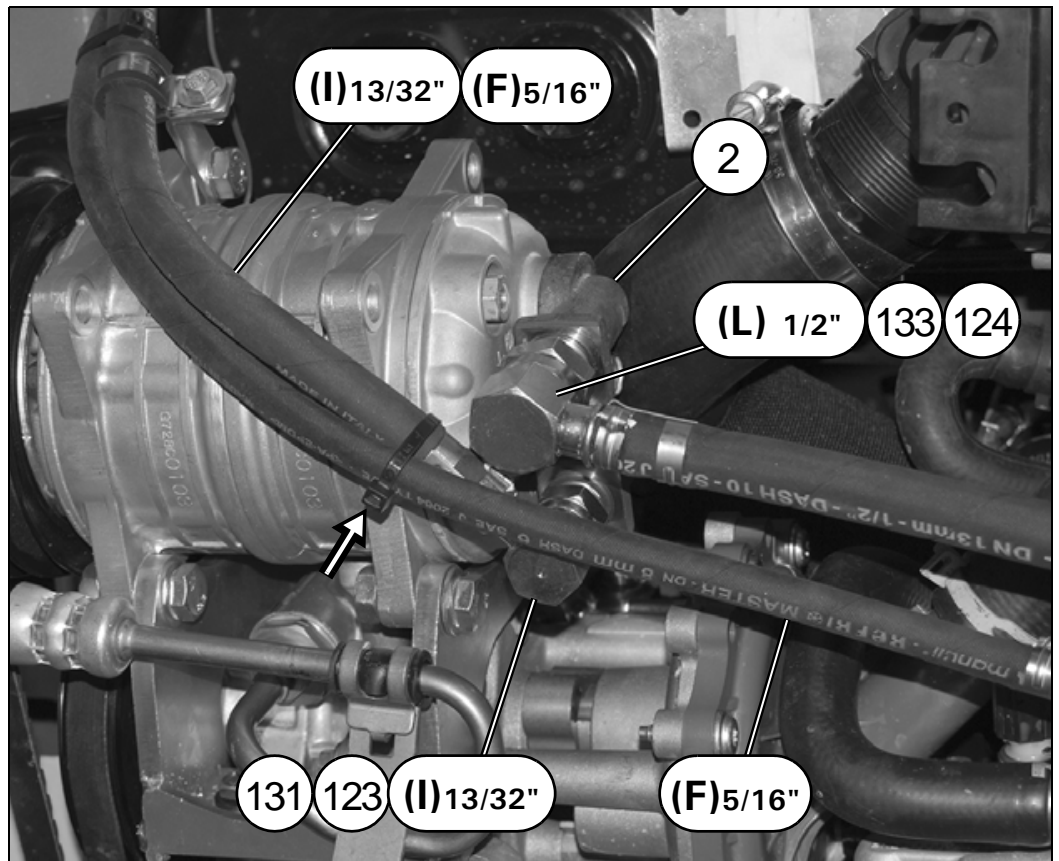

ELEMENTI DI FISSAGGIO / PIECES DE FIXATION / FIXING PARTS BEFESTIGUNGSELEMENTE / ELEMENTOS DE FIJACION		
Pos.	Tipologia / Typologie / Typology Tipologie / Tipologia	Descrizione / Description / Description Beschreibung / Descripción
➔		Fascetta a strappo

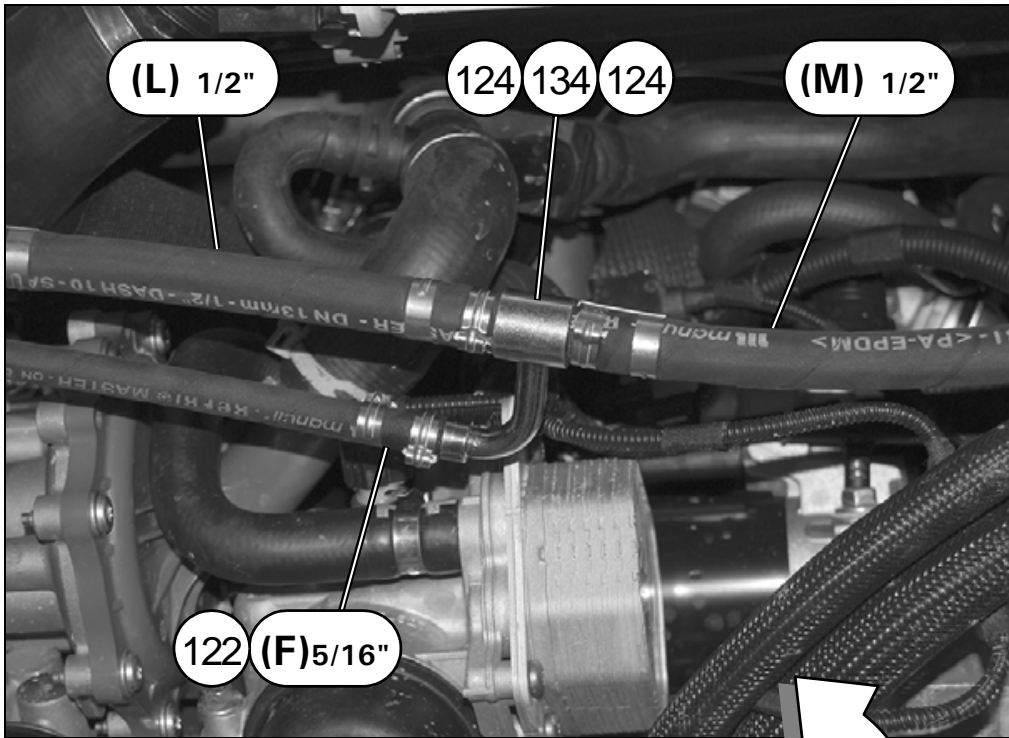

+ OPTIONAL KIT

19F

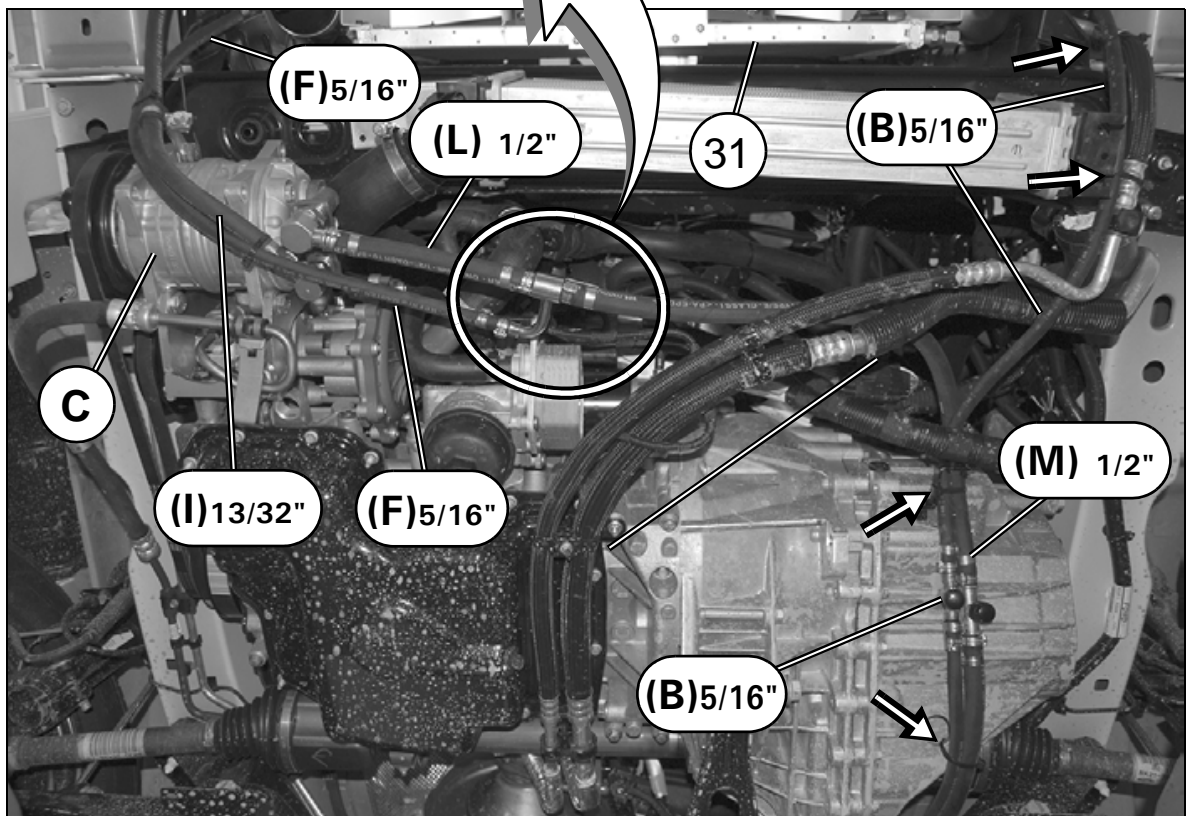

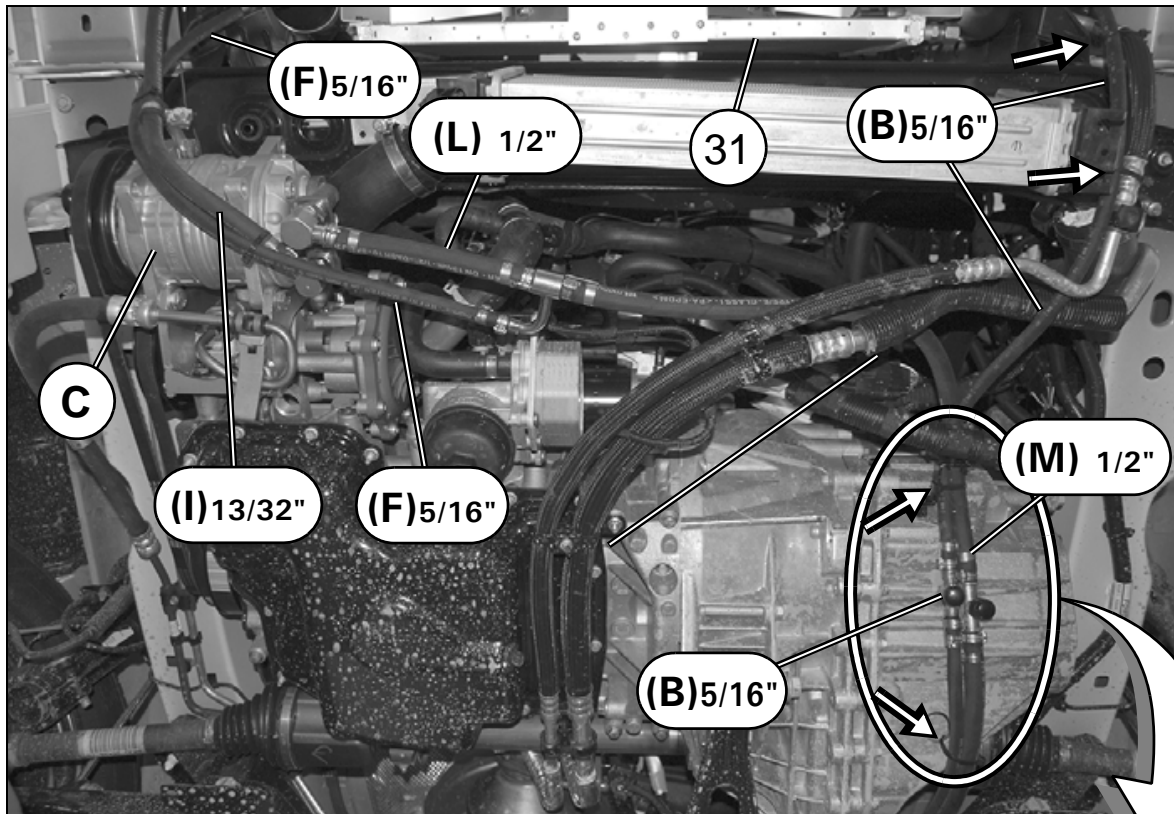

20F

+ OPTIONAL KIT

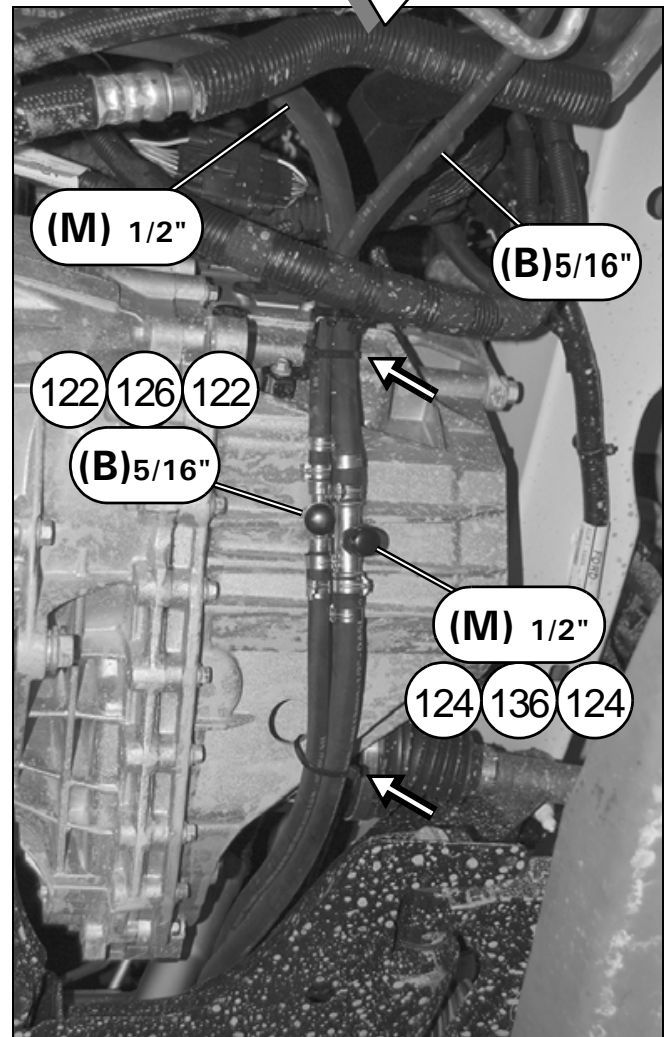

ELEMENTI DI FISSAGGIO / PIÈCES DE FIXATION FIXING PARTS / BEFESTIGUNGSELEMENTE ELEMENTOS DE FIJACION		
Pos.	Tipologia / Typologie Typology / Tipologie Tipologia	Descrizione / Description Description / Beschreibung Descripción
		Fascetta a strappo

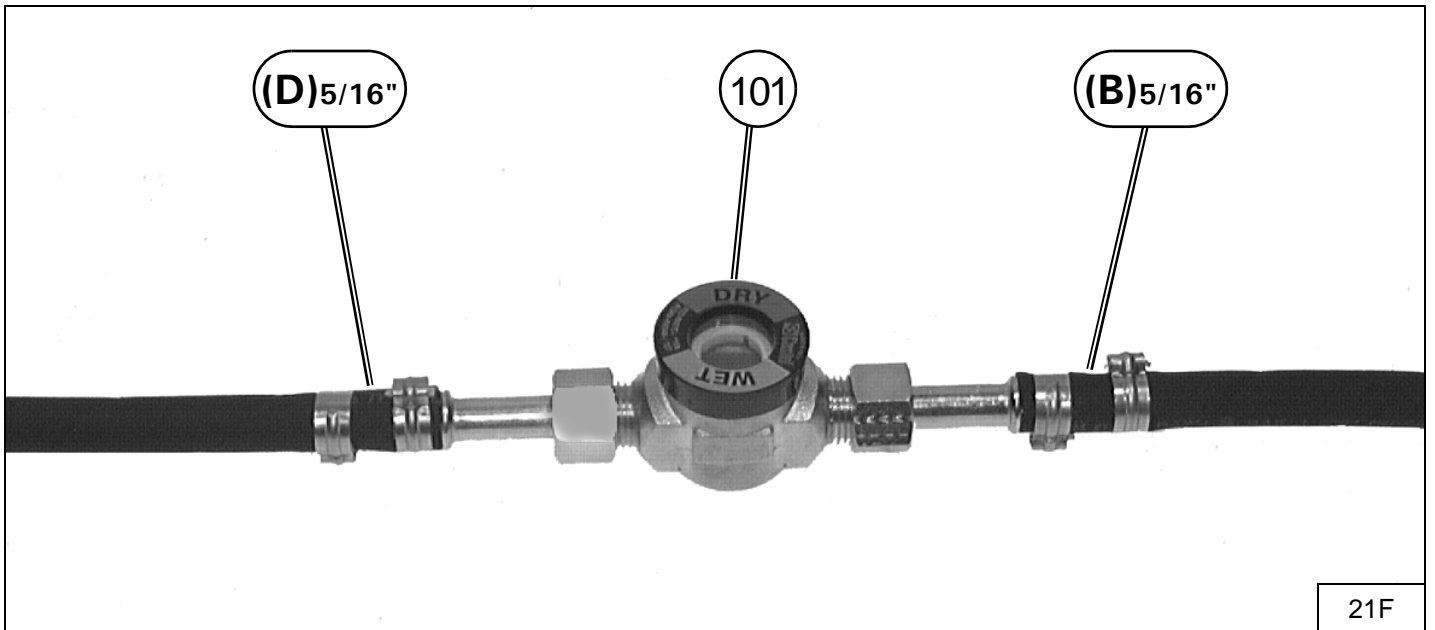

+ OPTIONAL KIT

(I) Inserire l'indicatore di passaggio liquido e umidità "101" lungo il tubo gas 5/16", diretto verso il gruppo refrigerante DIAVIA FRIGO "61", alloggiandolo cura dell'installatore, in una posizione adeguata per il controllo dello stato del refrigerante attraverso il vetro spia predisposto.

(F) Insérer l'indicateur de passage de liquide et d'humidité "101" le long du tuyau de gaz 5/16", dirigé vers le groupe réfrigérant DIAVIA FRIGO "61", l'installateur aura soin de le placer, dans une position adéquate pour le contrôle de l'état du réfrigérant à travers le verre témoin existant.

(GB) Insert the fluid flow and humidity indicator "101" along the 5/16" gas hose running to the DIAVIA FRIGO refrigeration unit "61". The installer must set it in a position so that it is possible to check the condition of the refrigerant passing through the arranged sight glass.

(D) Den Flüssigkeits- und Feuchtigkeitsanzeiger "101" entlang des zur Kühlgruppe DIAVIA FRIGO "61" führenden 5/16" Kältemittelschlauchs, durch einen Installateur sorgfältig einführen und in einer angemessenen Position unterbringen, um den Stand des Kühlmittels durch das vorhandene Kontrollfenster aus Glas ablesen zu können.

(E) Introducir el indicador de paso de líquido y humedad "101" a lo largo del tubo gas 5/16", en dirección al grupo refrigerante DIAVIA FRIGO "61", el instalador lo ha de colocar en una posición adecuada para controlar el estado del refrigerante a través del cristal espía predispuesto.

POSIZIONAMENTO IMPIANTO ELETTRICO NEL VANO MOTORE (vedi schema elettrico allegato)
POSITIONNEMENT DU FAISCEAU ELECTRIQUE DANS LE COMPARTIMENT MOTEUR (voir schéma électrique joint)
POSITIONING THE ELECTRIC SYSTEM WIRING WITHIN THE ENGINE COMPARTMENT (see the enclosed wiring diagram)
POSITIONIERUNG DER ELEKTRISCHEN ANLAGE IM MOTORRAUM (siehe Schaltschema im Anhang)
COLOCACIÓN DE LA INSTALACIÓN ELÉCTRICA EN EL ESPACIO MOTOR (véase esquema eléctrico adjunto)

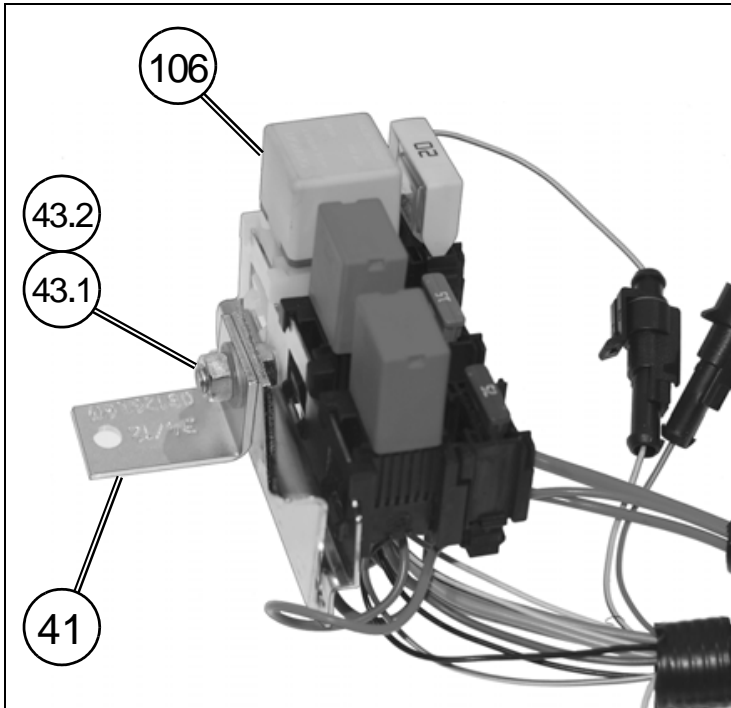

ELEMENTI DI FISSAGGIO / PIECES DE FIXATION FIXING PARTS / BEFESTIGUNGSELEMENTE ELEMENTOS DE FIJACION		
Pos.	Tipologia Typologi Typology Typologie Tipologia	Descrizione Description Description Beschreibung Descripción
43.1		M6x12
43.2		M6

22F

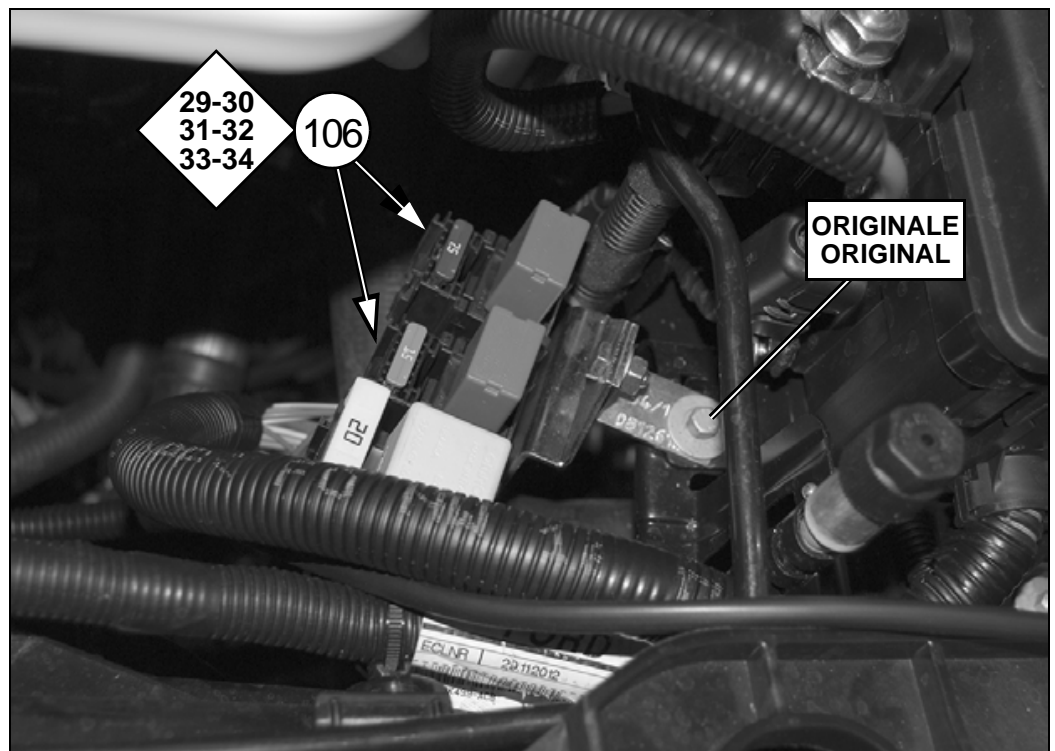

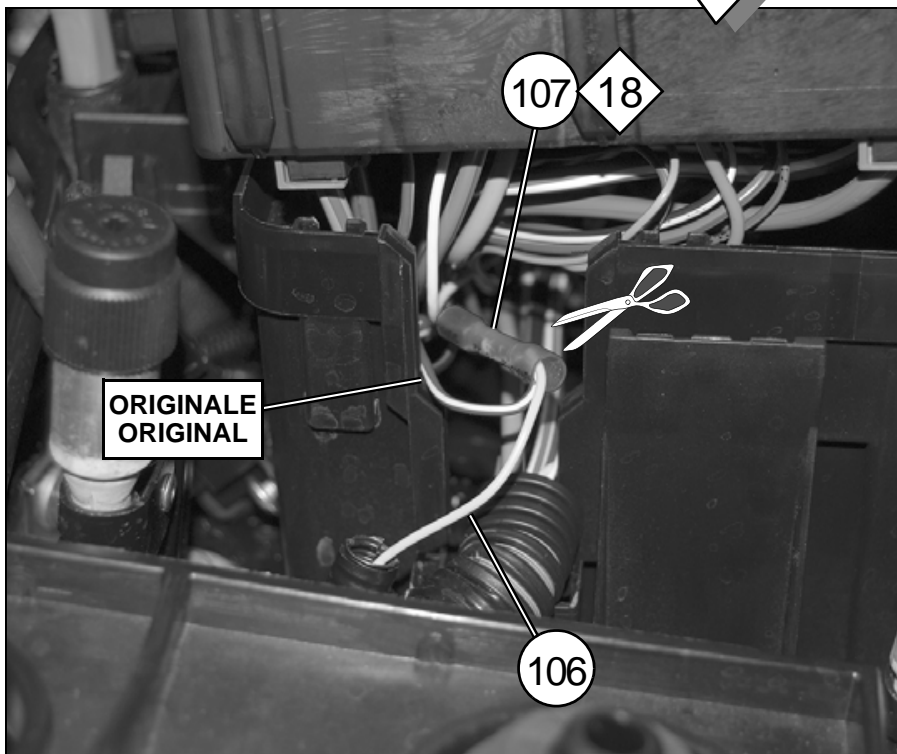
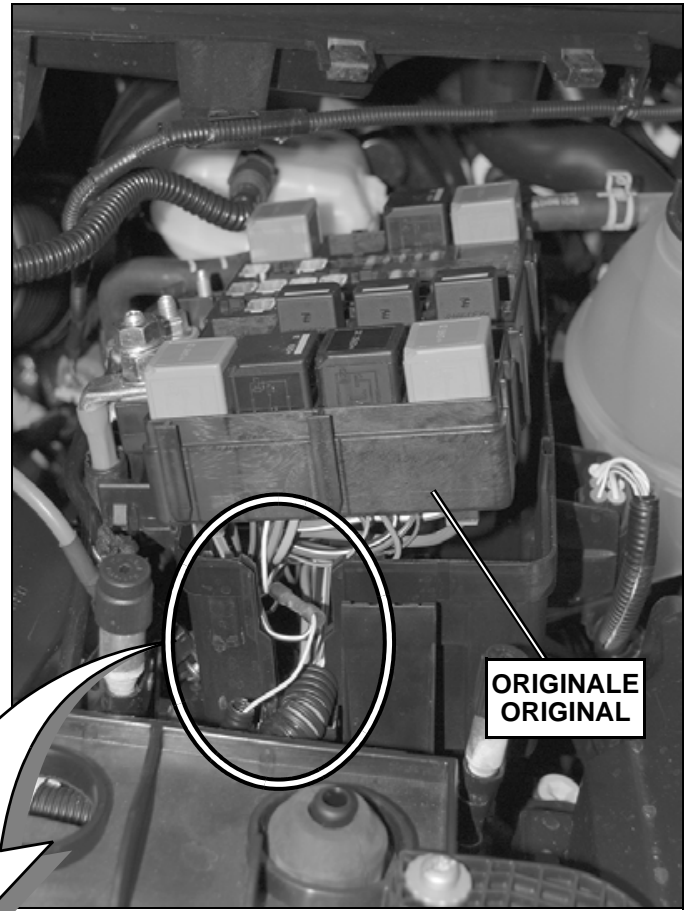

23F

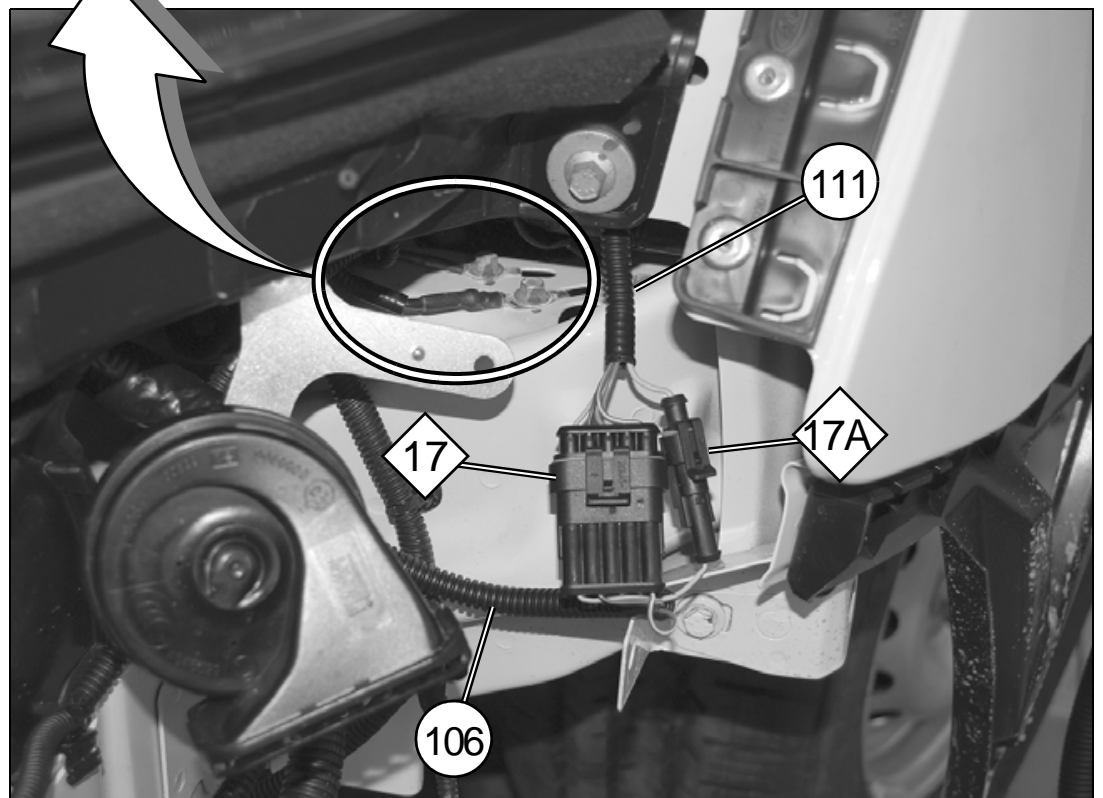
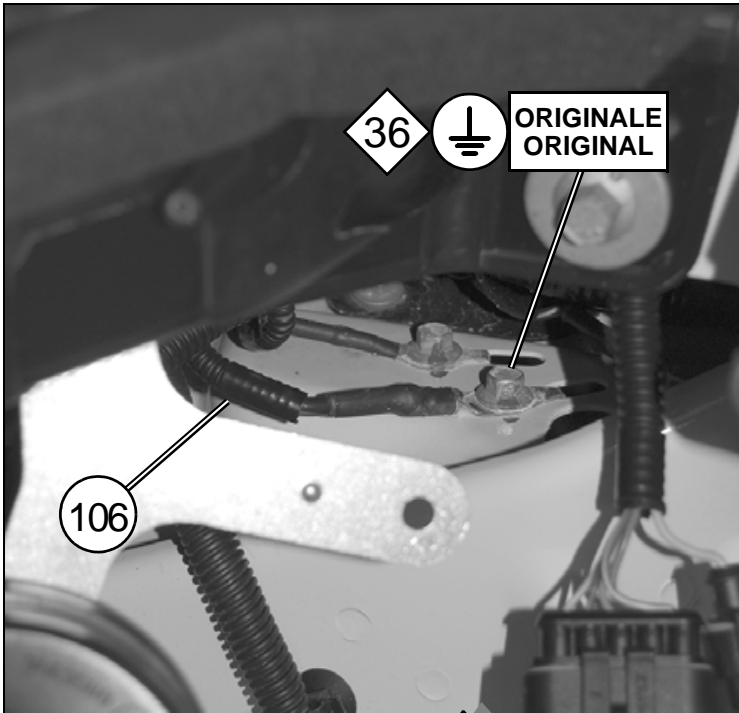

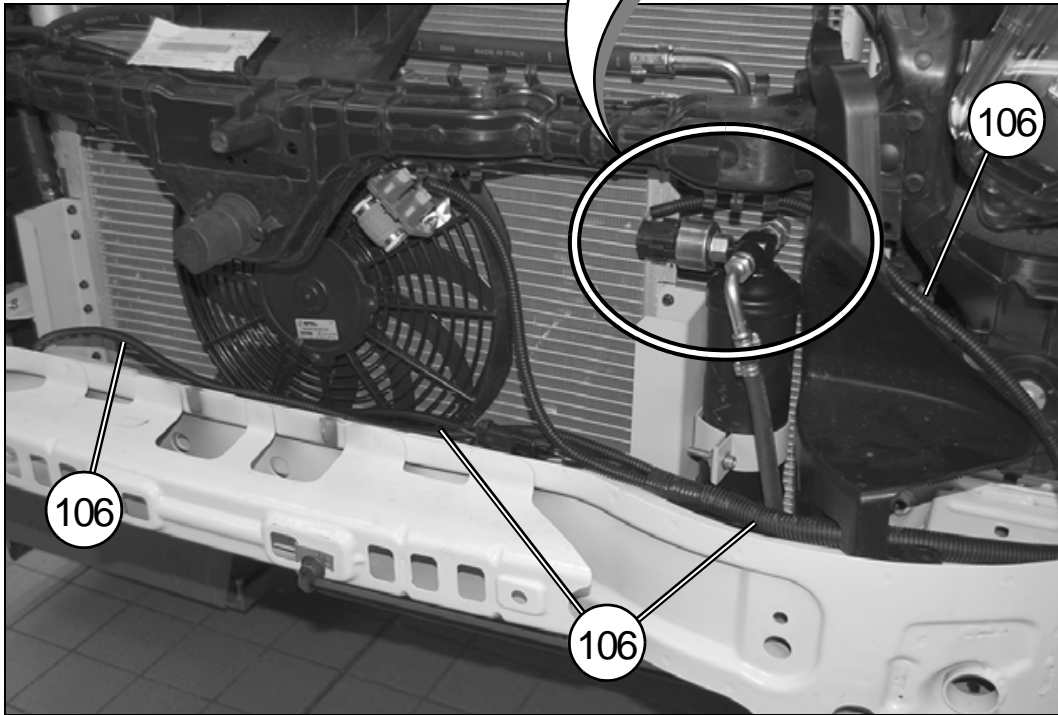
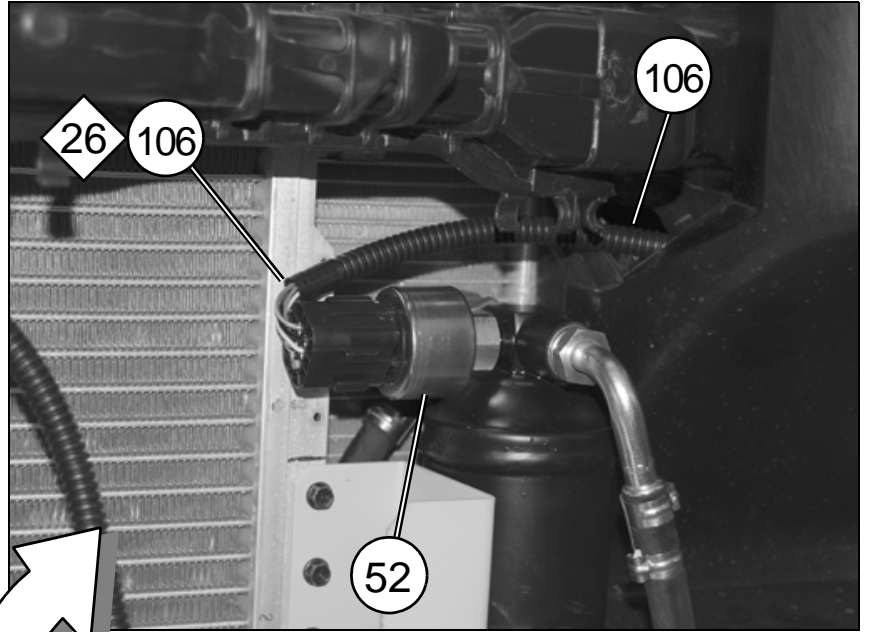

25F

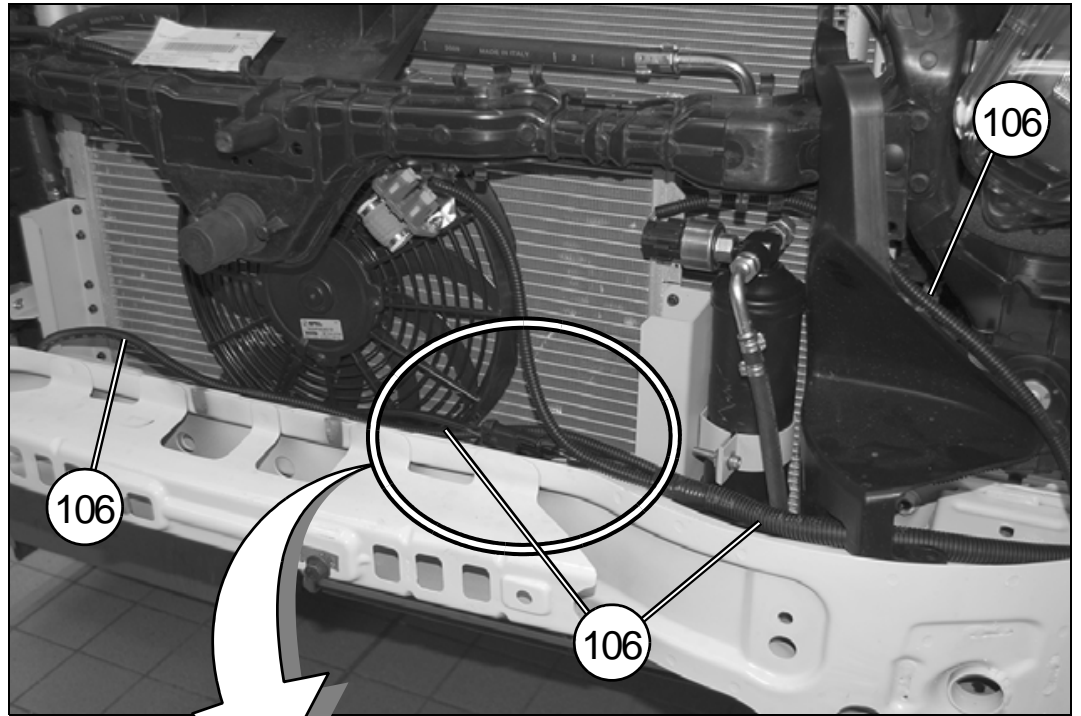

26F

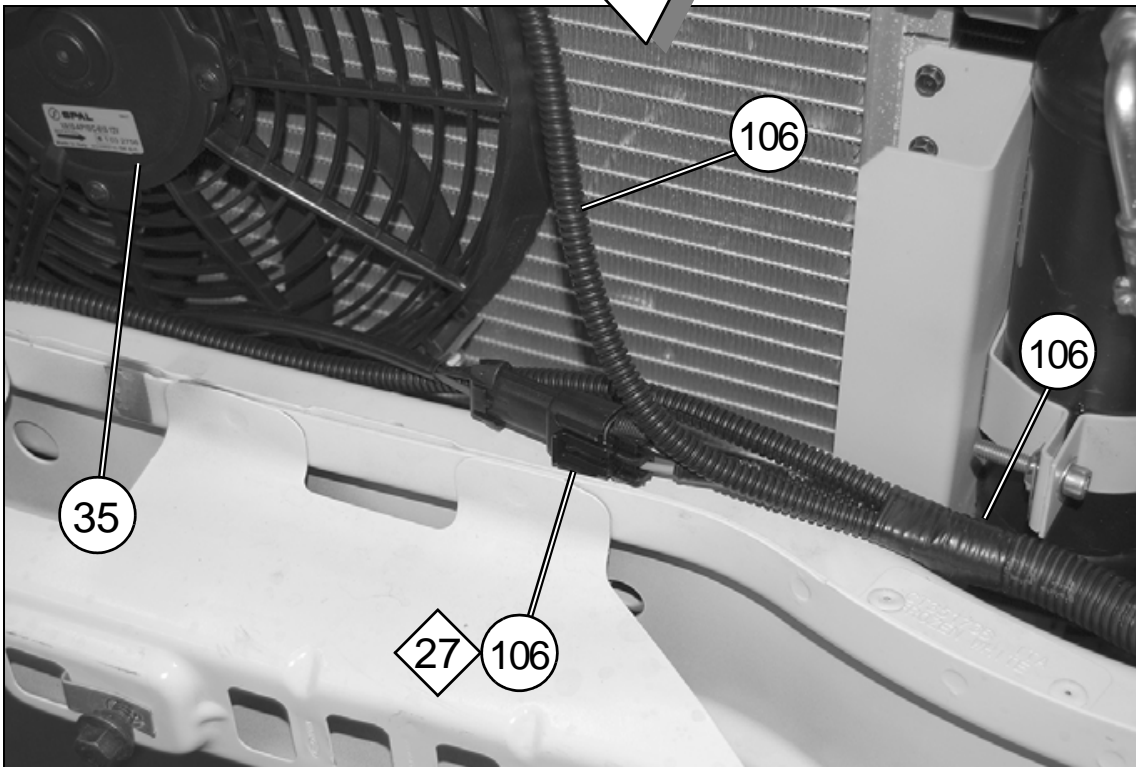

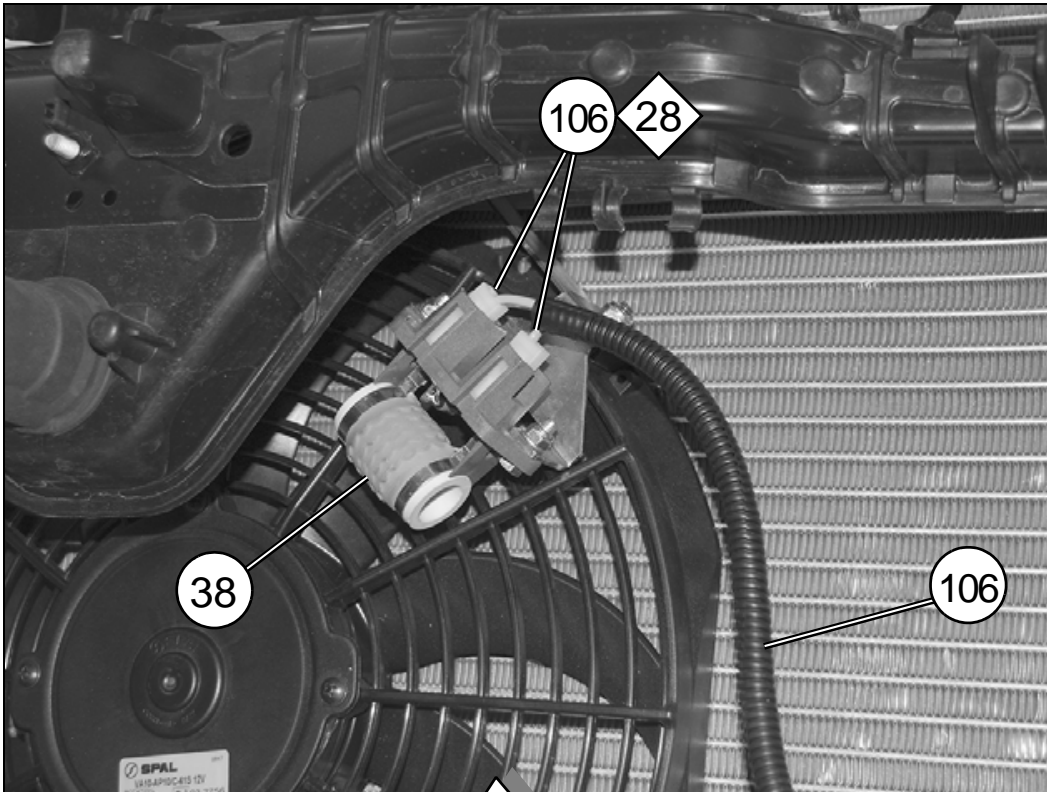

27F



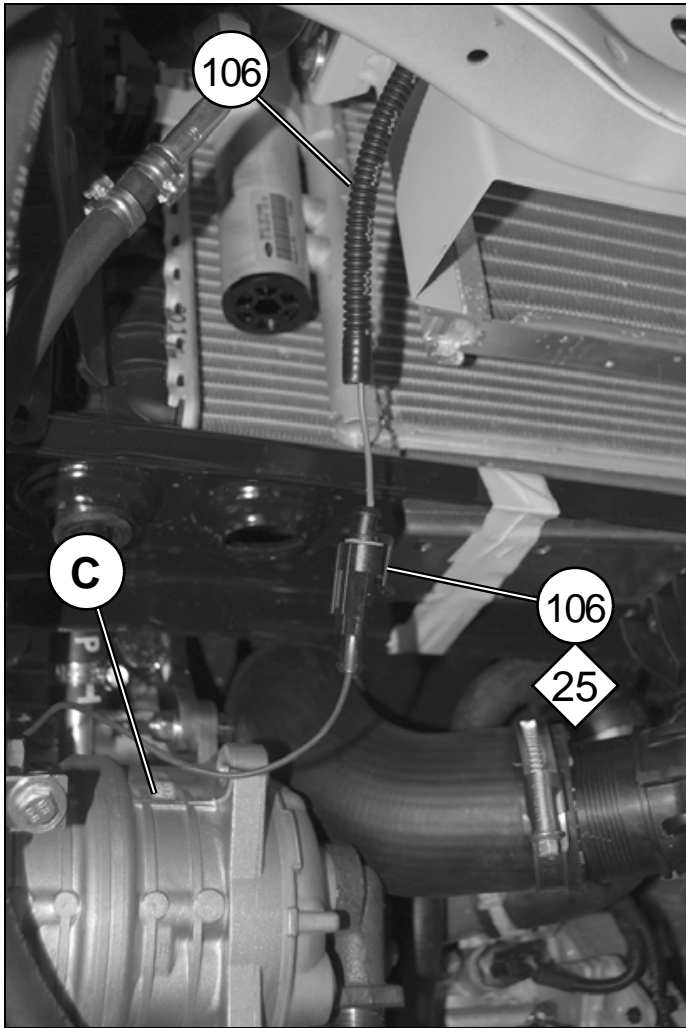

28F

29F

INSERIRE AD INCASTRO
INSERER PAR EMBOITEMENT
TO INSERT TO JOINT
EINKLEMMEN
INSERIR A ENCASTRE

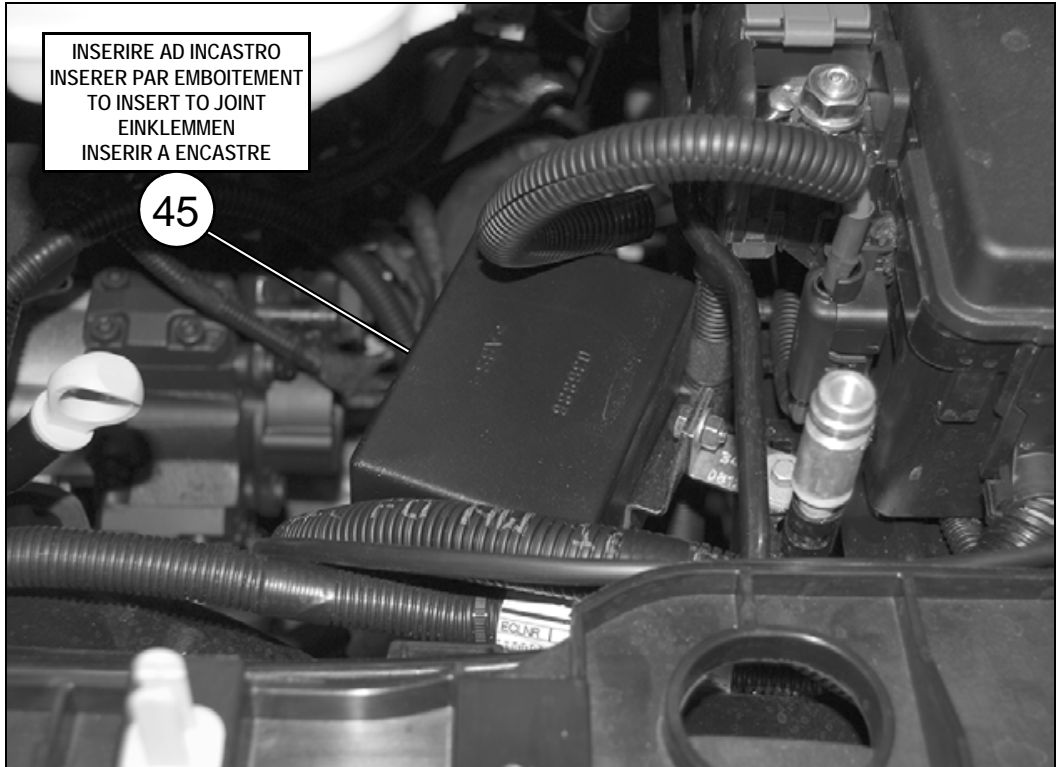

DAVIA FRIGO "MY 2007"

**Soluzione abbinamento impianti elettrici - solution accouplement faisceaux electriques - wiring systems mismatch solution
Verbindungsversion der Elektrischenanlagen - Solución acoplamiento instalaciones electricas**

14/11/06

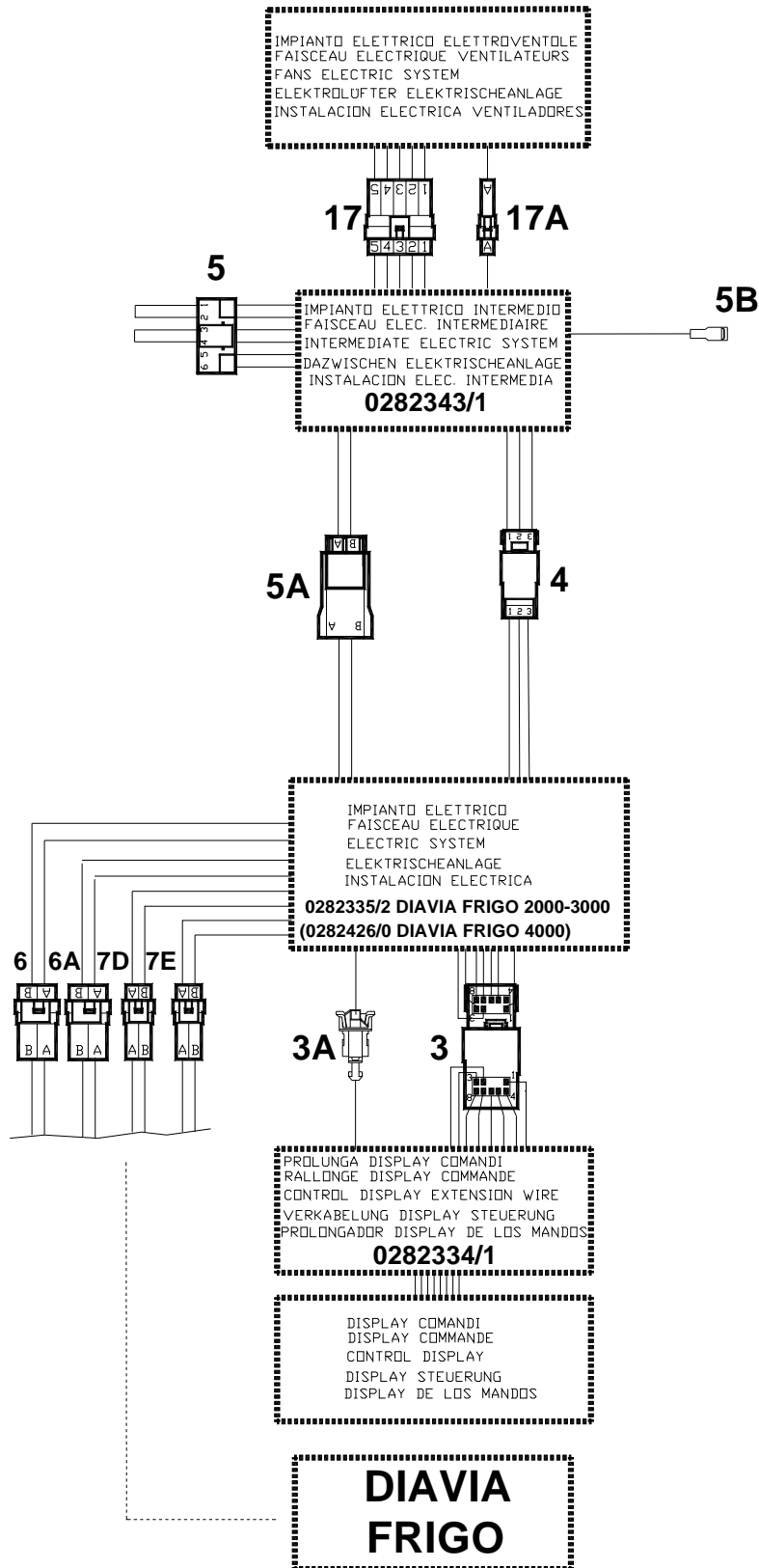

**SCHEMA IMPIANTO ELETTRICO / SCHEMA DE L'INSTALLATION ELECTRIQUE / WIRING DIAGRAM
SCHEMA DER ELEKTRISCHEN ANLAGE / ESQUEMA INSTALACION ELECTRICA
DIAVIA FRIGO " MY2007 "**

20-11-06

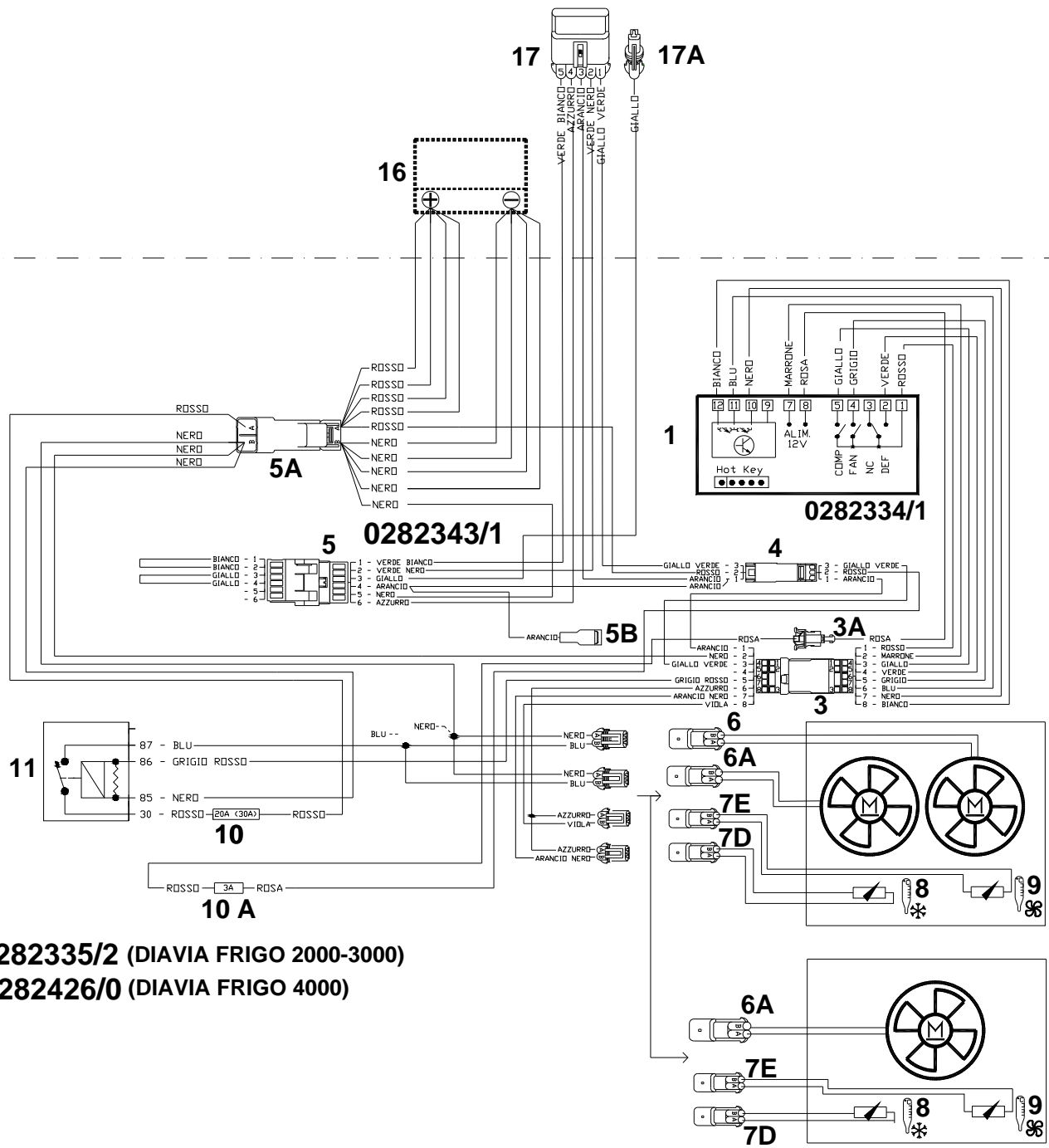

0282335/2 (DIAVIA FRIGO 2000-3000)
0282426/0 (DIAVIA FRIGO 4000)

SC019 - DIAVIA FRIGO MY2007 - 36 - DIXELL - MI-EB

N.	Descrizione / Description / Description Beschreibung / Descripción	Funzione / Fonction / Function Funktion / Función
1	Centralina Dispositif de contrôle Control unit Gehäuse Centralita	Controllo temperatura Côntrôle de la température Temperature control Temperatur-Kontroll Control temperatura
3	Connettore 8 vie Connecteur à 8 voies 8-way connector 8-weg-Steckverbinder Conector 8 vías	Collegamento con impianto evaporatore Connexion au faisceau électrique évaporateur Connection to evaporator electric wiring Anschluß mit Verdampfer Elektroanlage Conexión con instalación evaporador
3A	Connettore 1 via Connecteur à 1 voie 1-way connector 1-Weg-Steckverbinder Conector 1 vía	
4	Connettore 3 vie Connecteur à 3 voies 3-way connector 3-weg-Steckverbinder Conector 3 vías	Collegamento con +CHIAVE (+15) e segnale relay compressore Connexion avec +CLE (+15) et signal relais du compresseur Connection with +KEY (+15) and compressor relay signal Verbindung mit +SCHLÜSSEL (+15) und Kompressor Relay Signal Conexión con +LLAVE (+15) y señal realais compressor
5	Connettore 6 vie Connecteur à 6 voies 6-way connector 6-Weg-Steckverbinder Conector 6 vías	
5A	Connettore 2 vie Connecteur à 2 voies 2-way connector 2-Weg-Steckverbinder Conector 2 vías	
5B	Connettore 2 vie Connecteur à 2 voies 2-way connector 2-weg-Steckverbinder Conector 2 vías	Non utilizzare A ne pas utiliser Not to be used Nicht benützen A no utilizar
6	Connettore 2 vie Connecteur à 2 voies 2-way connector 2-weg-Steckverbinder Conector 2 vías	Collegamento con elettroventola Connexion au électroventilateur Connection to electric fan Anschluß mit Elektrolüfter Conexión con electroventilador
6A	Connettore 2 vie Connecteur à 2 voies 2-way connector 2-weg-Steckverbinder Conector 2 vías	Collegamento con elettroventola Connexion au électroventilateur Connection to electric fan Anschluß mit Elektrolüfter Conexión con electroventilador
7D	Connettore 2 vie Connecteur à 2 voies 2-way connector 2-weg-Steckverbinder Conector 2 vías	Collegamento con sonda temperatura (DEFROST) Connexion au sonde temperature (DEFROST) Connection to temperatur sensor (DEFROST) Anschluß mit temperature-Fühler (DEFROST) Conexión con sonda temperatura (DEFROST)
7E	Connettore 2 vie Connecteur à 2 voies 2-way connector 2-weg-Steckverbinder Conector 2 vías	Collegamento con sonda temperatura (Cella) Connexion au sonde temperature (Cellule) Connection to temperatur sensor (Cell) Anschluß mit Temperature-Fühler (Zellen) Conexión con sonda temperatura (Celda)
8	Sonda temperatura (DEFROST) Sonde temperature (DEFROST) Temperatur sensor (DEFROST) Temperature-Fühler (DEFROST) Sonda temperatura (DEFROST)	

9	Sonda temperatura (Cella) Sonde temperature (Cellule) Temperatur sensor (Cell) Temperature-Fühler (Zellen) Sonda temperatura (Celda)	
10	Fusibile 20A (30A) Maxi Fusible 20A (30A) Maxi 20A (30A) Fuse Maxi Schmelzsicherung 20A (30A) Maxi Fusible 20A (30A) Maxi	
10A	Fusibile 3A Fusible 3A 3A Fuse Schmelzsicherung 3A Fusible 3A	
11	Relay interruttore 70A Relais de coupure 70A 70A Switch Relay Relais-Schalter 70A Realais interruptor 70A	Comando elettroventola Comande electroventilateur Electric fan control Elektrolüfter Steuerung Comando electroventilador
16	Batteria / Batterie / Battery / Batterie / Bateria	
17	Connettore 5 via Connecteur à 5 voies 5-way connector 5-weg-Steckverbinder Conector 5 vías	Interfaccia impianto elettrico interno-esterno Interface installation électrique intérieure-extérieure Inner-outer electric system interface Elektrische Anlageninnenfläche innen-auben Frente instalación eléctrica interior-exterior
17A	Connettore 1 via Connecteur à 1 voie 1-way connector 1-weg-Steckverbinder Conector 1 vía	Interfaccia impianto elettrico interno-esterno Interface installation électrique intérieure-extérieure Inner-outer electric system interface Elektrische Anlageninnenfläche innen-auben Frente instalación eléctrica interior-exterior
18	Giunzione RAYCHEM ROSSO Raccord RAYCHEM ROUGE RED RAYCHEM connector RAYCHEM Verbindung ROT Junta RAYCHEM ROJO	Collegamento con +CHIAVE (+15) Connexion avec +CLE (+15) Connection with +KEY (+15) Anschluß mit +SCHLÜSSEL (+15) Conexión con +LLAVE (+15)
19	Scatola porta fusibili Boîte à fusibles Fuse box Schmelzsicherungskasten Caja porta-fusibles	
22	Connettore 2 vie Connecteur à 2 voies 2-ways connector 2-Weg-Steckverbinder Conector 2 vías	
23	Elettroventola Electroventilateur Fan Elektrolüfter Eléctroventilador	Raffreddamento radiatore e condensatore Refroidissement radiateur et condenseur Radiator and condenser cooling Kühler- und Kondensatorkühlung Enfriamiento radiador y condensador
25	Giunto elettromagnetico compressore Embrayage électromagnétique du compresseur Compressor electromagnetic clutch Elektromagnetische Kupplung des Kompressors Junta electromagnética del compresor	
26	Pressostato Pressostat Pressure switch Druckwächter Presostato	Protezione impianto A/C Protection équipement A/C A/C system safety device Klimaanlagen-Überlastungsschutz Protección de la instalación A/C

27	Elettroventola Electroventilateur Fan Elektrolüfter Eléctroventilador	Raffreddamento radiatore e condensatore Refroidissement radiateur et condenseur Radiator and condenser cooling Kühler- und Kondensatorkühlung Enfriamiento radiador y condensador
28	Resistore / Resisteur / Resistor / Widerstand / Resistor	
29	Relay interruttore Relais de coupure Switch Relay Relais-Schalter Realais interruptor	Comando giunto elettromagnetico compressore Commande l'embrayage électromagnétique du compresseur Compressor electromagnetic clutch control Steuerung der elektromagnetischen Kupplung des Kompressors Comando junta electromagnética compresor
30	Fusibile 7.5A Fusible 7.5A 7.5A Fuse Schmelzsicherung 7.5A Fusible 7.5A	
31	Relay interruttore Relais de coupure Switch Relay Relais-Schalter Realais interruptor	
32	Fusibile 20A Fusible 20A 20A Fuse Schmelzsicherung 20A Fusible 20A	
33	Relay interruttore Relais de coupure Switch Relay Relais-Schalter Realais interruptor	Comando elettroventola n. 23 (1. velocità) Commande électroventilateur n.23 (1° vitesse) Controls electric fan no.23 (1st speed) Steuerung des Elektrolüfter N. 23 (1. Geschwindigkeit) Comando eléctricoventilador n. 23 (1° velocidad)
34	Fusibile 20A Maxi Fusible 20A Maxi 20A Max Fuse Schmelzsicherung 20A Maxi Fusible 20A Maxi	
35	Connettore 1 via Connecteur à 1 voie 1-way connector 1-Weg-Steckverbinder Conector 1 vía	
35A	Connettore 1 via Connecteur à 1 voie 1-way connector 1-Weg-Steckverbinder Conector 1 vía	Collegamento per impianti con gas R134a Connexion pour équipement avec gaz R134a Connection for systems with R134a gas Anschluß für Kühlmittelanlagen R134a Conexión para instalaciones con gas R134a
35B	Connettore 1 via Connecteur à 1 voie 1-way connector 1-Weg-Steckverbinder Conector 1 vía	Collegamento per impianti con gas R404a Connexion pour équipement avec gaz R404a Connection for systems with R404a gas Anschluß für Kühlmittelanlagen R404a Conexión para instalaciones con gas R404a
36	Punto di massa originale Point de masse d'origine Original ground point Original-Massepunkt Punto de masa original	
38	Logica funzionamento elettroventola Logique fonctionnement électroventilateur Electric fan logic Betriebslogik der Elektrolüfter Logica funcionamiento electroventilador	

(I)
N.B.:
 Le parti in tratteggio rappresentano componenti dell'impianto elettrico originale.

(F)
N.B.:
 Les parties hachurées représentent des composants du faisceau électrique d'origine.

(GB)
N.B.:
 The dashed parts represent components of the original electric system.

(D)
N.B.:
 Die gestrichelten Teile stellen Bauteile der ursprünglichen Anlage dar.

(E)
N.B.:
 Les partes discontinuas representan componentes de la instalación eléctrica original.

ITALIANO	FRANCAIS	ENGLISH	DEUTSCH	ESPANOL
Arancio	Orange	Orange	Orange	Naranjado
Azzurro	D'azur	Light blue	Hellbrau	Azul
Bianco	Blanc	White	Weiss	Blanco
Blu	Bleu	Blue	Blau	Turqui
Giallo	Jaune	Yellow	Gelb	Amarillo
Grigio	Gris	Gray	Grau	Gris
Marrone	Marron	Brown	Braun	Marron
Nero	Noir	Black	Schwarz	Negro
Rosa	Rose	Pink	Rosa	Rosa
Rosso	Rouge	Red	Rot	Rojo
Verde	Vert	Green	Grün	Verde
Viola	Violet	Violet	Violett	Violado

(I)
Webasto Diavia mira ad un costante miglioramento dei propri prodotti. La Casa si riserva il diritto di apportare in qualunque momento e senza preavviso modifiche ai modelli e ai componenti descritti in questa pubblicazione per ragioni di natura tecnica o commerciale. Per ulteriori informazioni rivolgersi al servizio assistenza Webasto Diavia.

(F)
Webasto Diavia vise à une amélioration constante des ces produits. La maison se réserve le droit d'apporter, à tout moment et sans préavis, des modifications aux modèles et aux composants décrits dans cette publication pour des raisons d'ordre technique ou commerciale. Pour d'ultérieures informations s'adresser au service d'assistance Webasto Diavia.

(GB)
Webasto Diavia focuses on constant upgrading of its products. The Manufacturer reserves the right to modify the models and components described in the present publication at any time for technical or commercial reasons and without prior notice. For further information, contact Webasto Diavia technical services.

(D)
Webasto Diavia ist stets bestrebt die eigenen Produkte zu verbessern. Die Herstellerfirma behält sich das Recht vor, aus technischen oder Verkaufsgründen, zu jeder Zeit und ohne vorherige Ankündigung, Abänderungen an den Modellen und den in dieser Veröffentlichung beschriebenen Einbauteile vorzunehmen. Für weitere Informationen bitten wir Sie, sich an unseren Webasto Diavia Kundendienst zu wenden.

(E)
Webasto Diavia aspira a un constante mejoramiento de su producción. La Fábrica se reserva el derecho de aportar en cualquier momento y sin preaviso modificaciones a los modelos y los componentes descritos en esta publicación por razones técnicas o comerciales. Para ultiores informaciones dirigirse al servicio asistencia Webasto Diavia.

VENDITA E SERVIZIO
VENTE ET SERVICE

VERKAUF UND SERVICE
SALE AND SERVICE

WEBASTO THERMO & COMFORT ITALY S.r.l.

Via Nobili, 2 40062 Molinella C.P. 69 (Bologna) - Italy

Telefono (0039) 051.6906316

Fax (0039) 051.6906287

Email: diavia.service@webasto.com



MOD. SCHFO302

VII / '13
(2013)

Questa pubblicazione è stata curata da Webasto Diavia
Ufficio Documentazione AM - Stabilimento Molinella

This publication has been edited by Webasto Diavia
AM Documentation Office - Factory Molinella