

SPMA32 / SPMA35

SPMA MODELS

ASYMMETRIC ELECTROMECHANICAL LIFT FEATURING COLUMNS AT 45°.

Thanks to the asymmetric design of the columns, the loading areas of the arms overlap, granting great flexibility and time saving when picking up the vehicle.

- + Easy door opening
- + Quick car positioning
- + More room for moving around



SPMA32

The geometry of the arms has been designed to lift from micro-cars to long wheel base sedan.

Capacity

3.2 t

SPMA35

The geometry of the arms has been designed to lift from micro-cars to long wheel base medium vans.

Capacity

3.5 t

HIGHLIGHTS IN DETAIL



1 The vehicle can be placed backward without any worries about damaging the vehicle itself.

2 The operator has at his disposal a wide loading area, without the necessity of pushing and pulling the vehicle to find the right lifting position.

3 The lift is designed to have the same total width as the standard lift but with a greater drive though.

4 Controlled up/down by pushing button positioned at an ergonomic height.

SPMA32 / SPMA35

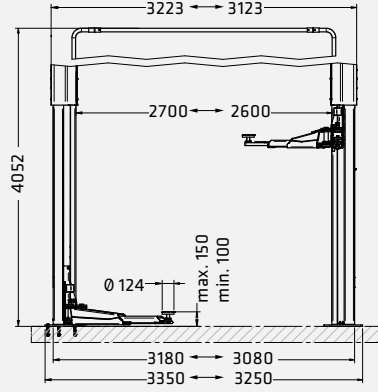
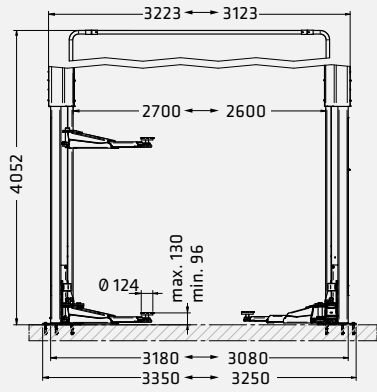

Model	SPMA32	SPMA35
Capacity	3200 kg	3500 kg
Max. lifting height	2000 mm	2000 mm
Lifting time	42 s	42 s
Min. pad height	96 mm	100 mm
Max. pad height	130 mm	150 mm
Column height	3223 mm	3223 mm
Drive-through width	2372-2472 mm	2372-2472 mm
Min. ceiling height	4150 mm	4150 mm
Arm layout	asimétrica	asimétrica
Min. front arm length	555 mm	564 mm
Max. front arm length	1100 mm	1160 mm
Min. rear arm length	805 mm	922 mm
Max. rear arm length	1200 mm	1460 mm
Driving power	2x2.6 kW	2x3.5 kW
Width	3250-3350 mm	3250-3350 mm
Height	4052 mm	4052 mm

Item no.	Energy kit	Double control panel	TEq-Link
ROT.SP32X.198549			✓
ROT.SP32X.198723	✓	✓	✓
ROT.SP35X.199263			✓
ROT.SP35X.198990	✓	✓	✓

Technical changes reserved. Data are considered advertisement.
2-Post-Lift-SPM32/SPM35-BR-131206-en-2022-08

