



**Techni**  
ENGINEERING SOLUTIONS

**FORD  
ALL-NEW TRANSIT VAN  
290 / 310 / 330 / 350**

---

**CODE / CODICE: 0500.7722**

**COMPRESSOR / COMPRESSEUR / KOMPRESSOR  
/ COMPRESSORE / COMPRESOR :**

**SELTEC: TM13 / 15 / 16**

**QUE: QP13 / 15 / 16**

**SANDEN: SD7H15**

---

**FITTING INSTRUCTIONS**

**EINBAUANLEITUNGEN**

**INSTRUCTIONS POUR LE MONTAGE**

**ISTRUZIONI DI MONTAGGIO**

**INSTRUCCIONES DE MONTAJE**

---



**Contents**

<b>ENGLISH</b> .....	4
Parts View.....	4
Parts List .....	5
Compressor Configurations .....	6
Standard Fastener Torque Values .....	6
Kit Details .....	7
Vehicle Details .....	7
Forward .....	7
Pre Installation.....	8
Installation .....	10
Drive Pulley Installation.....	10
Bracket Installation .....	12
Front and Rear Supports .....	13
Compressor Installation.....	13
Compressor Belt .....	14
Intercooler Hose.....	15
PAS Hoses.....	16
Post-Installation .....	17

PARTS VIEW / VUE ÉCLATÉE / TEILEANSICHT / VISTA PARTA / IMÁGENES DE LAS PIEZAS

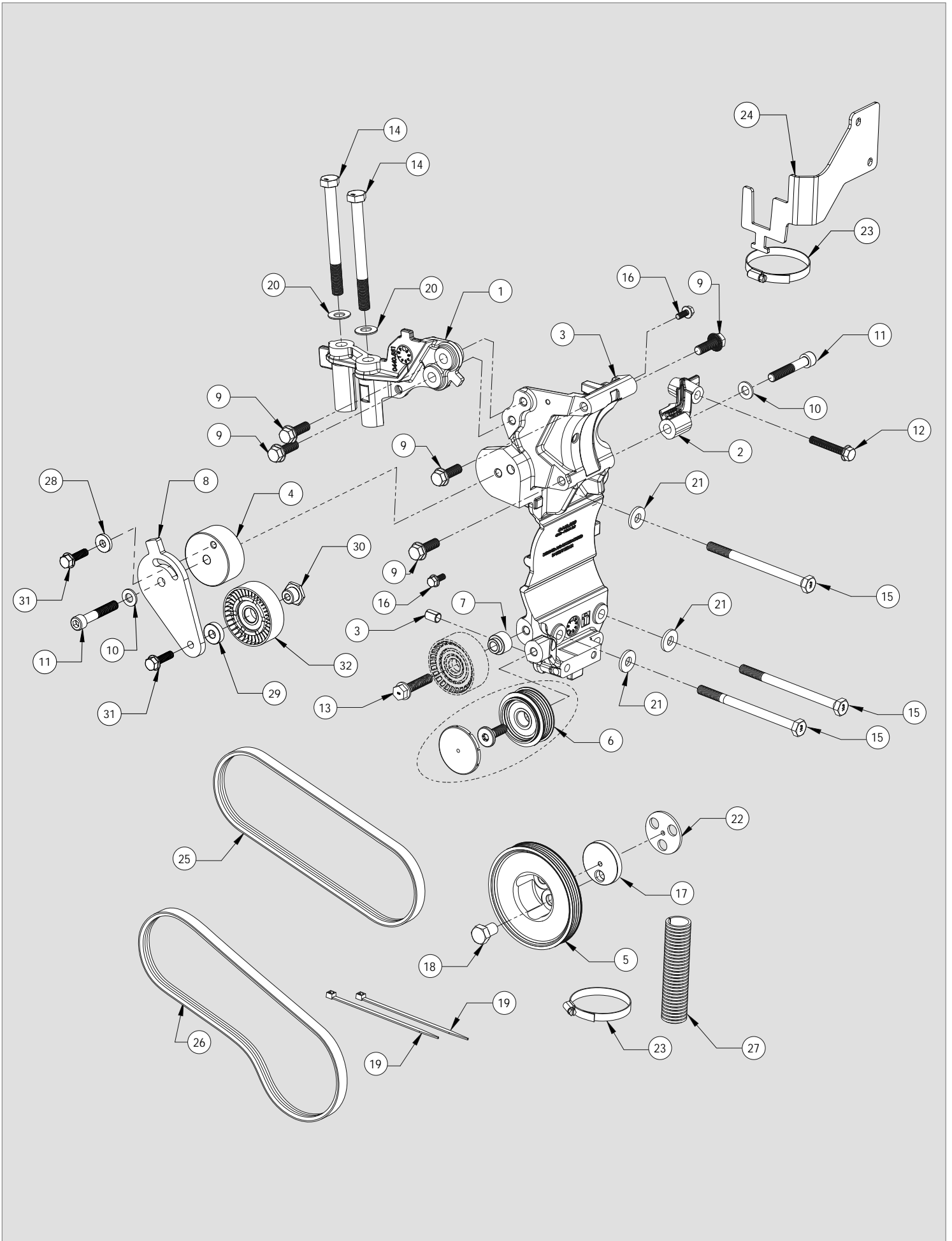

## PARTS LIST / NOMENCLATURE / TEILELISTE / ELENCO DELLE PARTI / LISTA DE PIEZAS

ITEM	CODE / CODICE / KODE / CODIGO	DESCRIPTION / DESCRIZIONE / BESCHREIBUNG / DESCRIPCION	QTY.	COMMENTS
1	0440.5511	Front Support Bracket PUMA 2.2 (Ford)	1	
2	0440.5521	Rear Support Bracket PUMA 2.2 AC	1	
3	0441.5501	CMB Assy PUMA 2.2 AC	1	
4	2803.6141	Adjuster Base	1	
5	1701.5431	Crankshaft Drive Pulley PUMA 2.2 FWD AC Ø119mm	1	
6	1700.5351	4PK Idle Pulley Ø60 (Included Cap & Bolt)	1	
7	2803.6071	Idle pulley spacer Ø23 L15 Ø10.5	1	
8	3020.6461	Adjuster Plate	1	
9	2705.0491	Hex flange bolt Durlok - M10 x 30 : 1.50 - 12.9	5	
10	2809.0011	Washer M10 Flat DIN 125 - A 10.5	2	
11	2705.5051	Hex socket head cap screw M10 x 60 : 1.50 - 12.9	2	
12	2704.0101	Hex flange bolt - M8 x 50 : 1.25 - 10.9	1	
13	2705.0401	Hex Flange Bolt -M10 x 45 : 1.50 -10.9	1	
14	2706.5081	Hex Bolt M12x130 : 1.25 - 10.9	2	
15	2705.5381	Hex Bolt M10x140 : 1.5 -10.9	3	
16	2702.0131	Hex flange bolt Durlok - M6 x 16 : 1.00 - 12.9	2	
17	2803.3773	Crankshaft Pulley Drilling Jig	1	
18	2723.0041	Set Screw 1/2 x 0.75 - 20 UNF	1	
19	2763.0051	Cable Tie 4.8 x 370 - Black	2	
20	2810.5001	Washer - M12 DIN - 2093A	2	
21	2803.0273	Washer - 25 x 10.5 x 3	3	
22	2803.5263	Crankshaft Pulley Spacer - SMF Cranshaft Only	1	
23	1537.1051	Hose Clamp - 50 - 70	2	
24	3020.6441	PAS Reservoir mount	1	
25	0820.7481	Belt - Poly Groove 4PK 922 Elast	1	
26	0820.7511	Belt - Poly Groove 4PK 1290	1	
27	1430.0092	Nylon Split Tube	1	
28	2808.5001	Washer M8 Flat DIN 7349 OD21 x ID8.4 x L4	1	
29	2803.6441	Spacer 24 OD x 9 ID x L7.5	1	
30	2803.5961	Pulley nut 24mm A/F	1	
31	2704.0091	Hex flange bolt Durlok - M8 x 30 : 1.25 - 12.9	2	
32	1700.5211	Back Idle Pulley	1	

**COMPATIBLE COMPRESSORS / COMPRESSEURS RECOMMANDÉS / EMPFOHLENE KOMPRESSOREN  
RACCOMANDATO COMPRESSORI / RECOMENDADAS COMPRESORES**

SELTEC	TM-13 HS	TM-15 HS	TM-16 HS
Comp No	0381.0202	0381.0002	0381.0312
Valeo No.	488-45120	488-55120	488-46134
Mounting	Ear	Ear	Ear
Rotor	8PV	8PV	8PV
GL	46.55mm	46.55mm	46.55mm
Armature	3E	3E	3E
Diameter	123	123	123
Voltage	12	12	12
Orientation	V	V	V
Fitting	3/4 x 7/8	3/4 x 7/8	3/4 x 7/8
Manifold	Bolt	Bolt	Bolt

QUE	QP-13 HS	QP-15 HS	QP-16 HS
Comp No	0391.0202	0391.0002	0391.0312
Que No.	QP13-1302	QP15-1171	QP16-1581
Mounting	Ear	Ear	Ear
Rotor	8PV	8PV	8PV
GL	46.55mm	46.55mm	46.55mm
Armature	3E	3E	3E
Diameter	123	123	123
Voltage	12	12	12
Orientation	V	V	V
Fitting	3/4 x 7/8	3/4 x 7/8	3/4 x 7/8
Manifold	Bolt	Bolt	Bolt

SANDEN	-	-	SD7H15
Comp No	-	-	0370.0061
Sanden No.	-	-	8103
Mounting	-	-	Ear
Rotor	-	-	8PV
GL	-	-	46.55
Armature	-	-	5L
Diameter	-	-	119
Voltage	-	-	12
Orientation	-	-	V
Fitting	-	-	3/4 x 7/8

NOTES

**STANDARD FASTENER TORQUE VALUES**

In the absence of specific torque values detailed in this fitting instruction manual, the following chart can be used as a guide to the maximum safe torque for specific size and grade of fastener.

**COUPLES DE SERRAGE DES FIXATIONS STANDARDS**

Si des chiffres de serrage au couple particuliers ne sont pas indiqués dans cette notice de montage, se référer au tableau suivant qui servira de guide pour le couple de sécurité maximum correspondant à une taille et un grade spécifiques de fixation.

**ANZIEHMOMENTE FÜR STANDARDBEFESTIGUNGSMITTEL**





Falls in dieser Einbauanleitung keine speziellen Anziehmomente angegeben sind, kann die folgende Tabelle als Richtlinie für das maximale sichere Anziehmoment für eine spezifische Größe oder Qualität von Befestigungsmitteln dienen.

**VALORI STANDARD DI SERRAGGIO PER DISPOSITIVI DI FISSAGGIO**

In assenza di valori specifici di coppia nel presente manuale di istruzioni, si può utilizzare la seguente tabella come guida per conoscere la coppia massima sicura in base a dimensioni e grado del dispositivo di fissaggio.

**VALORES ESTÁNDAR DE LOS PARES DE APRIETE Y FIJACIÓN**

En ausencia de valores para los pares de apriete específicos detallados en este manual de instrucciones de montaje, se puede utilizar la siguiente tabla como guía para consultar el máximo par de torsión seguro para un tamaño concreto y su grado de fijación.

STRENGTH								
	Max Torque		Max Torque		Max Torque		Max Torque	
Dia / Pitch	lb.ft	Nm	lb.ft	Nm	lb.ft	Nm	lb.ft	Nm
M5 x 0.80	2	3	4.5	6	6.5	9	7.5	10
M6 x 1.00	4	5.5	7.5	10	11	15	13	18
M8 x 1.25	10	13	18	25	26	35	33	45
M10 x 1.25	20	27	39	53	57	78	66	90
M10 x 1.50	18	25	37	50	55	73	63	86
M12 x 1.75	33	45	63	85	97	130	111	150
M14 x 2.00	55	75	103	140	151	205	177	240
M16 x 2.00	85	115	159	215	232	315	273	370

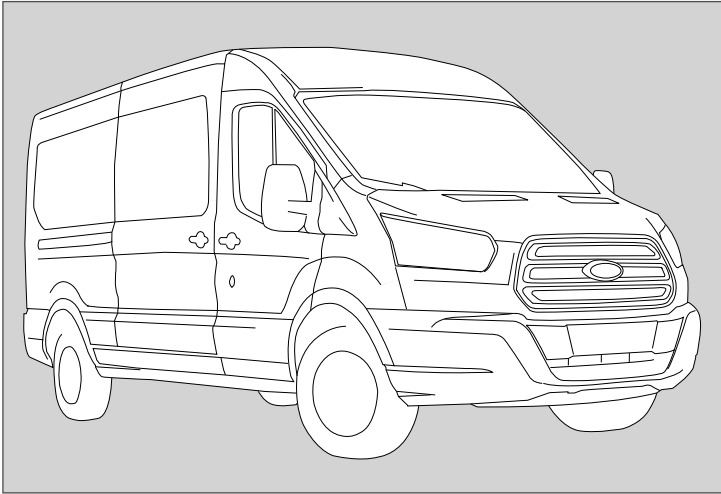

## VEHICLE DETAILS

Manufacturer	Ford
Model	All-New Transit Van
Model Type	290, 310, 330, 350
Engine	2.2 TDCi -100/125/155 PS
Engine Details	Euro 5b+ (stg V), Euro 6 (HDT Stg VI)
Year	04.2014>
Chassis Type.	V363
LHD	YES
RHD	YES
PAS	YES
A/C	YES
Voltage	12v

## KIT DETAILS

Kit Part No.	0500.7722
Description	Speed Reduction Kit
Compressor RPM	3410 @ Max engine power output
Fitting Time	180 Minutes
Suction Fitting	90°
Discharge Fitting	90°
Main Drive Belt	4PK 1290 / 4PK922
Belt Part No.	0820.7511 / 0820.7481
Note	

## FOREWORD

The purpose of this manual is to facilitate the installation of a direct drive compressor. The information given is merely instructive, should any complications arise contact the Technical department. The manufacturer's warranty does not cover any problems caused by defective installation or alterations made unless authorised. The manufacturer shall not be responsible for any injury, damage or loss caused directly or indirectly as a result of using this manual or the information contained within it.

### 1 SAFETY MEASURES:

**Before fitting the Compressor adapter drive kit, ensure the following for damage:**

- a Inner and outer trim and body work
- b Engine idle pace
- c Check all the vehicle functions

**Check list:**

- a Ensure that the right kit has been selected
- b Before installing, check that all the correct pieces are present; also ensure that there are no missing or broken pieces
- c When fitting, make sure the vehicle is properly protected against damage.

### Installation apparatus

- a Calibrated torque wrench
- b Hand service tools
- c Protective covers and shields

### 2 PRECAUTIONS

- a Detach the battery negative lead.
- b Torque all bolts where stated using a calibrated torque wrench.
- c Take extreme care with moving parts.
- d Remove the vehicle's ignition key and keep it with you.
- e Wear safeguards and make sure that liquid refrigerant never touches your skin

**Caution:** Measures must be followed accurately to steer clear of the possibility of damage to individuals

**Warning:** This calls awareness to actions which must be pursued to avoid damage to the components.

**NB:** This calls awareness to make the job easier or gives useful information.

**PRE-INSTALLATION**

**N.B** Prior to commencing work, please examine the instructions with care. The alphabetical symbols on the diagram relate to written instructions, numerical symbols relate to the parts listing.

**REMOVAL OF PARTS**

1. Disconnect the battery
2. Remove air filter assembly (A) - Fig 1

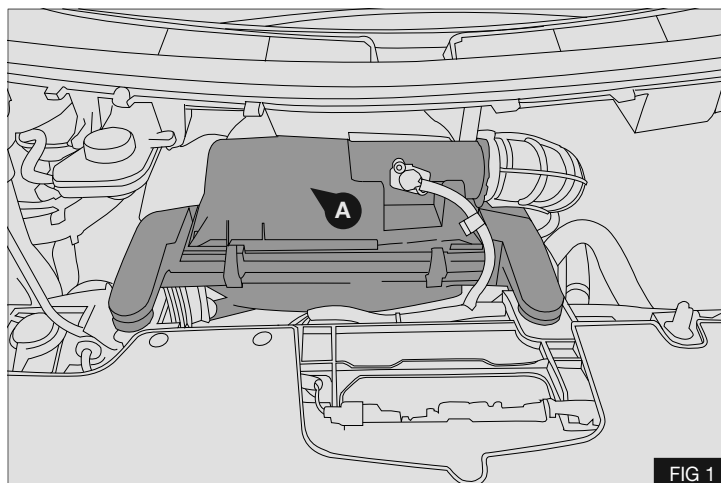

3. Pulley shield (B) - Fig 2
4. Guard below intercooler (C) - Fig 2

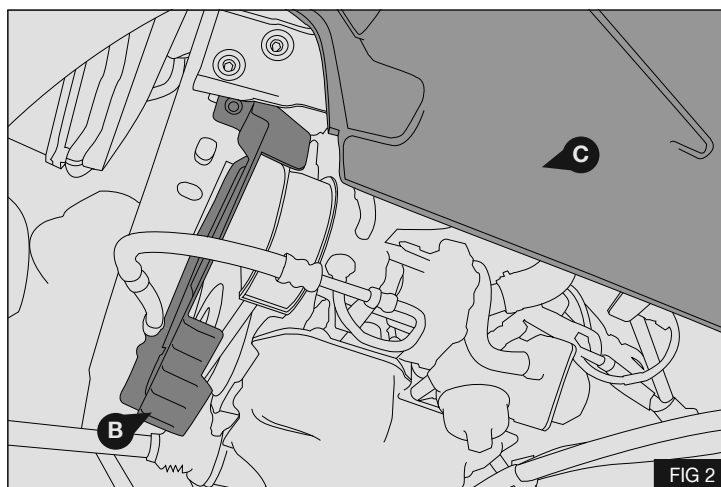

5. Discard Belt guard (D) - Fig 3
6. Intercooler duct (E) - Fig 3

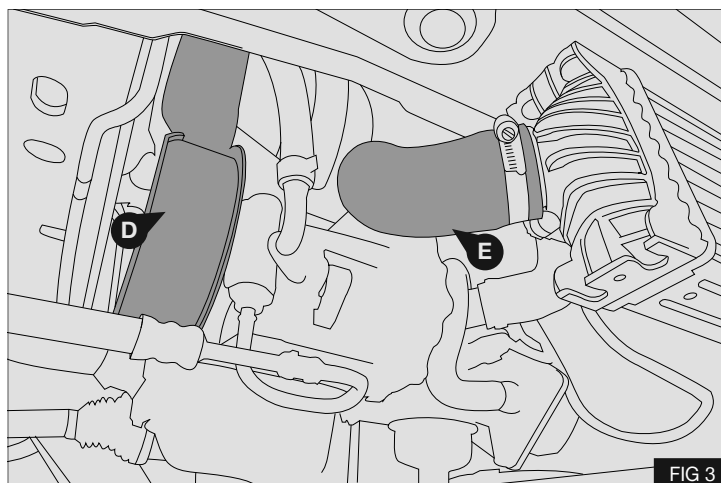

7. Discard PAS drive belt (F) - Fig 4
8. Release tension on auto belt tensioner (G) and lock using a Ø4mm pin. - Fig 4

**NOTE:** It is not necessary to completely remove the drive belt (H)

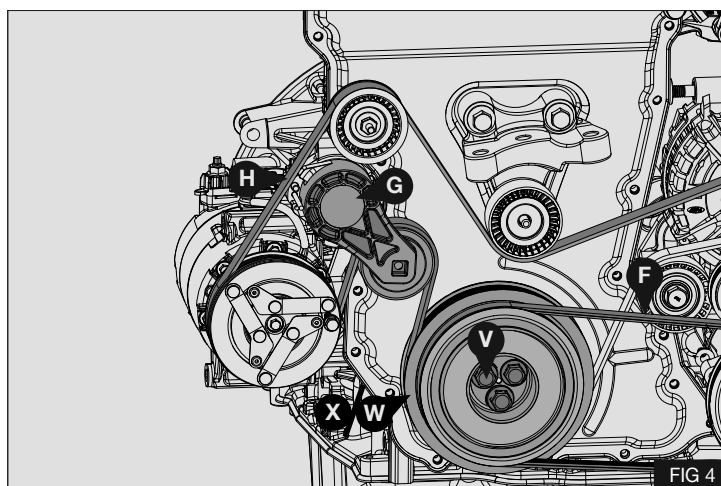



9. Remove the alternator  $\textcircled{X}$  discard fasteners - Fig 5

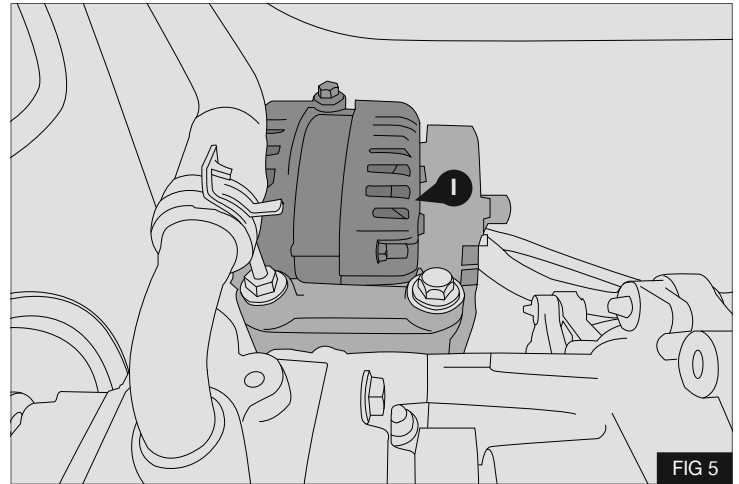

10. Position the alternator  $\textcircled{I}$  as shown ready for re-installation. - Fig 6

11. Slacken PAS pump lower mounting bolts  $\textcircled{J}$ . Remove and retain upper fixing bolts  $\textcircled{K}$  and  $\textcircled{L}$  - Fig 6

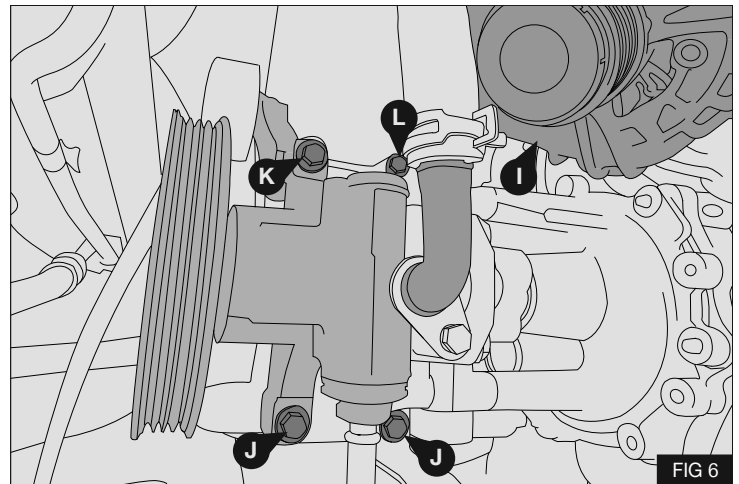

12. Remove PAS / Pulley mount  $\textcircled{N}$  retain its mounting bolt  $\textcircled{M}$  (not shown.) - Figs 7 & 6

13. Remove and retain pulley  $\textcircled{O}$  discard mount  $\textcircled{N}$

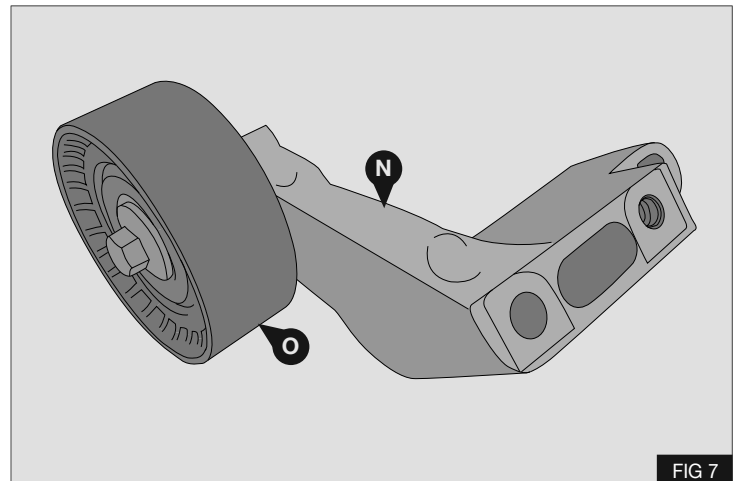

14. Remove M6 nut securing harness connector support bracket  $\textcircled{Q}$  and stud  $\textcircled{P}$  from timing case. The bracket  $\textcircled{Q}$  will secure to the compressor mount bracket later in the installation - Fig 8

15. Install M6x16 bolt  $\textcircled{16}$  into hole previously occupied by stud  $\textcircled{P}$ .

Torque bolt  $\textcircled{16}$  to 10 Nm / 7.5Lbft

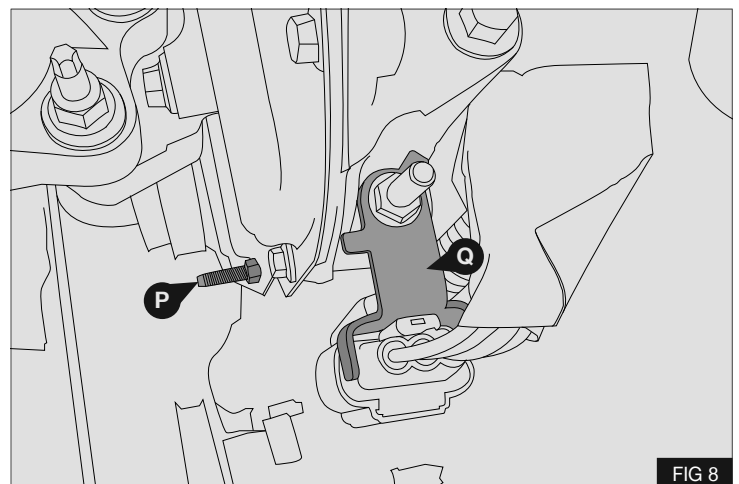

**Warning:** To avoid damage to the engine dual mass flywheel the subsequent method must be performed correctly. DO NOT LOCK THE ENGINE BY REMOVING THE CRANKSHAFT SENSOR

1. Temporarily remove the cable (R) to gain access to the starter motor bolts (S) - Fig 9
2. Temporarily remove the two bolts (S) securing the starter motor (T) - Fig 9

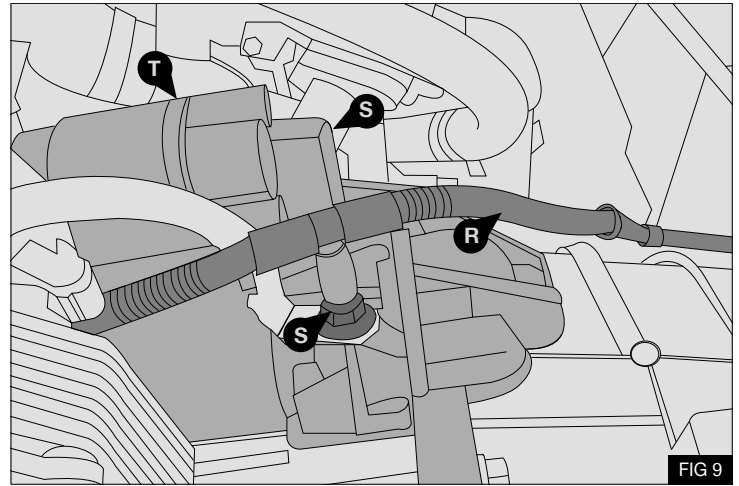

3. Move the starter motor to gain access to the flywheel ring gear (U) - Fig 10
4. Using a suitable tool lock the flywheel ring gear at point (U) - Fig 10

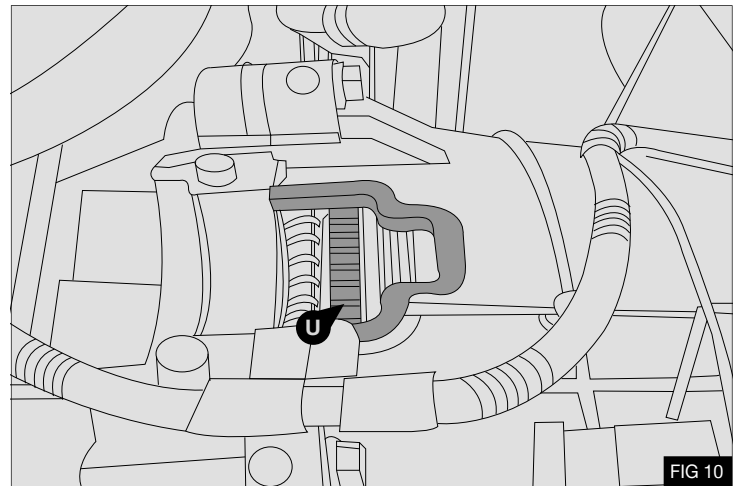

**Warning:** take care not to damage the flywheel Reluctor ring

5. Remove the 3x bolts (V) and remove the pulley (X/W) - Fig 4

## INSTALLATION

### DRIVE PULLEY INSTALLATION

1. Check the type of engine crankshaft damper fitted to the vehicle, Single mass flywheel (SMF) (X) or dual mass flywheel (DMF) (W) - Fig 11

**Warning:** If the vehicle crank pulley is different to the ones shown in the image please contact your mount kit supplier.

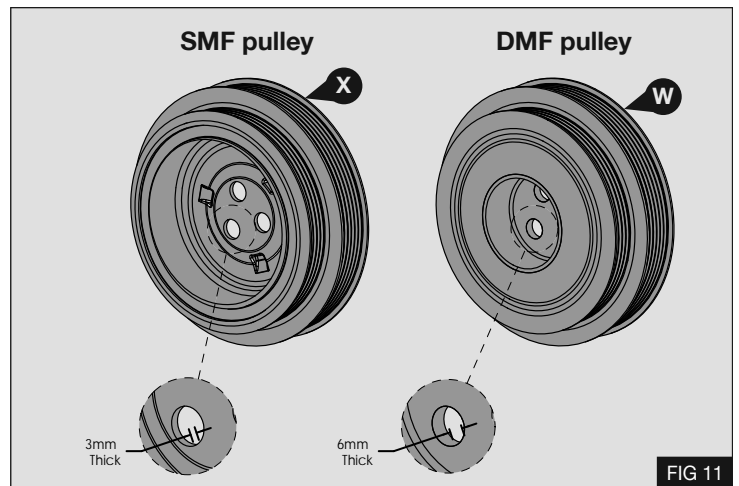

2. Mount the drilling jig (17) to the rear of the previously removed engine damper and secure with bolt (18) - Fig 12

**Warning:** Centralise the drilling jig (17) between the locating lugs on the damper.

3. Drill a Ø5mm hole through the original crankshaft pulley using the drilling jig as a guide. - Fig 12

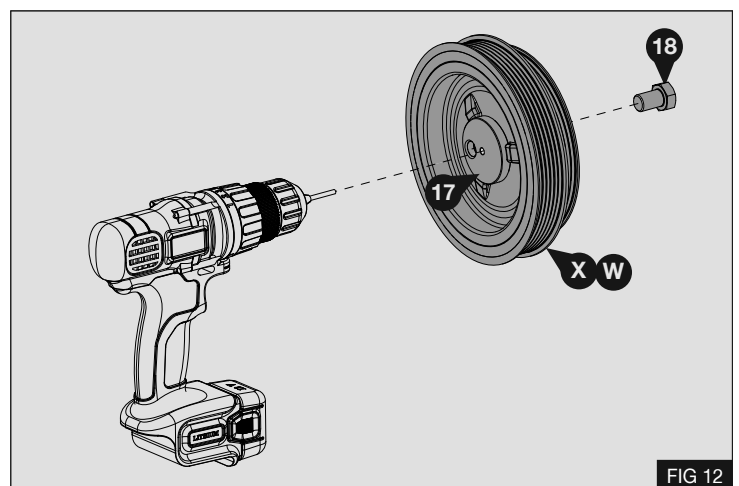

### Single mass flywheel (SMF) – Only

- Assemble crankshaft pulley (5) and spacer (22) onto original pulley (X) and fit to the vehicle securing with the original bolts (V) - Fig 13

**Caution:** Spacer (22) must be installed to provide correct belt alignment

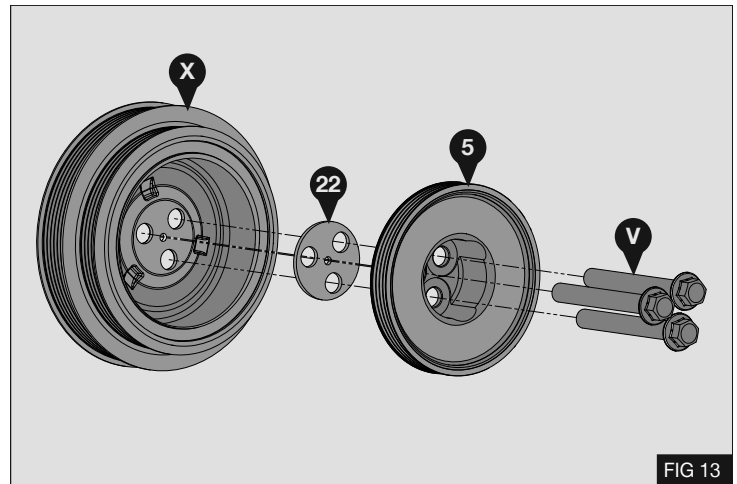

### Dual mass flywheel (DMF) – Only

- Assemble crankshaft pulley (5) onto original pulley (W) and fit to the vehicle securing with the original bolts (V) - Fig 14

**Warning:** Bolts are to be used 3 times only, each time they are removed they are to be centre punched to indicate they have been used.

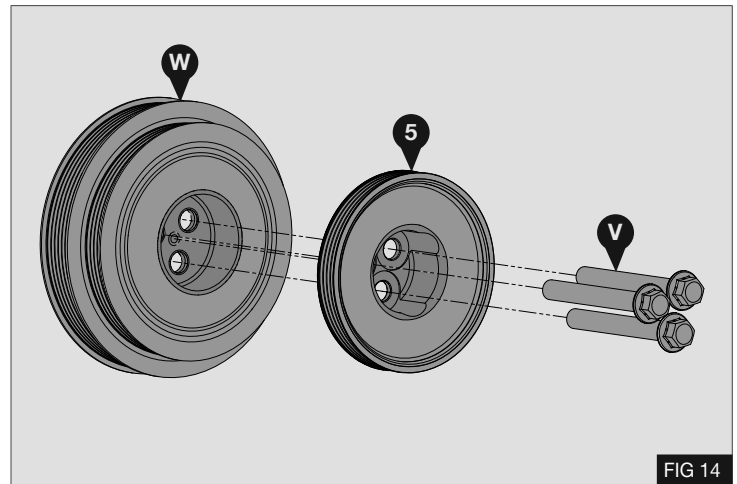

### Tightening procedure (SMF) and (DMF)

- Lock the starter ring gear and tighten the bolts (V) in the following sequence. - Fig 15

Stage 1- Torque bolts (V) to 45Nm / 33.2 Lbft





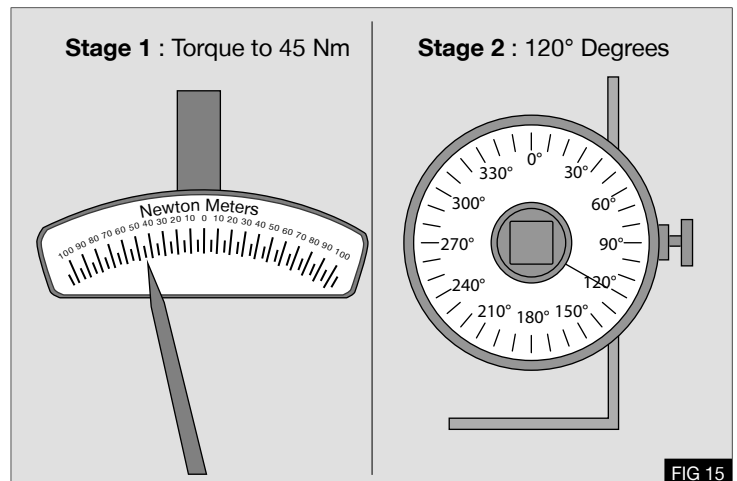

Stage 2- Tighten each bolt 120 Degrees.



- Re-fit the starter motor (T) with bolts (S) - Fig 9

Torque bolts (S) to 35Nm / 25.8Lbft





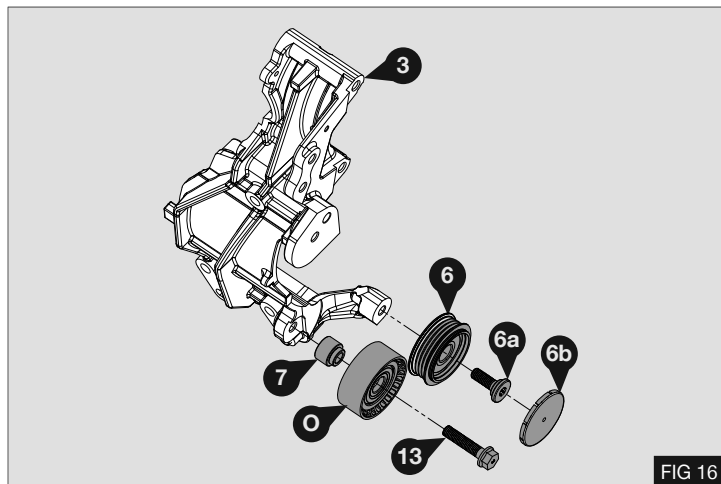

**BRACKET INSTALLATION**

1. Assemble pulley  onto bracket  using Bolt  and pulley cap  - Fig 16
2. Fit original idle pulley  using supplied bolt M10x45  and spacer  - Fig 16



Torque bolts  and  to 44.7Nm / 33 Lbft



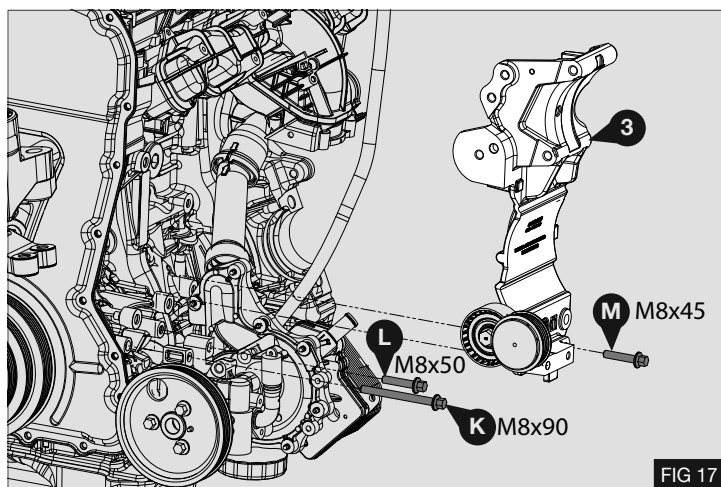

3. Insert bracket assembly  from above between the PAS pump and the engine block. Ensure locating dowel is correctly seated into the engine block, secure lower part of bracket using the original fasteners  (M8x90),  (M8x50) and  (M8x45) - do not tighten at this stage - Fig 17

**CAUTION:** USE THE CORRECT BOLTS IN THE CORRECT HOLES





4. Fit the alternator  using 3x M10x140 bolts  with washers  - Fig 18

**Note:** Insert bolts  into the alternator  prior to installing.

5. Torque bolts in the following order-

Torque Bolts  to 65Nm / 48 Lbft

Torque bolts    to 23Nm / 17 Lbft - Fig 17

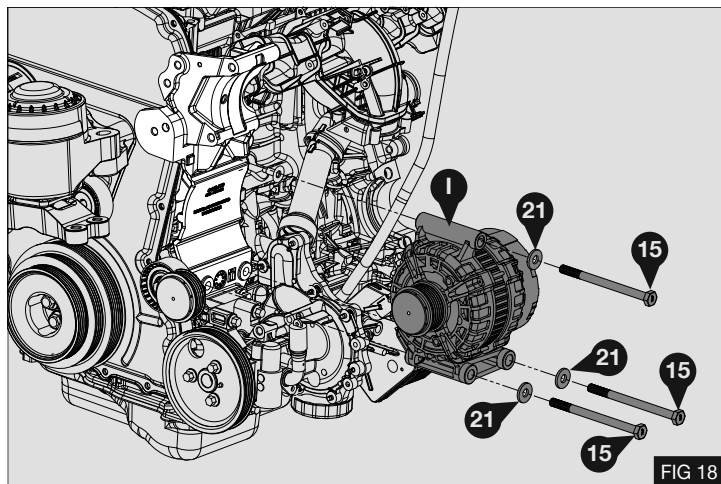

5. Re-fit OE drive belt  and release automatic belt tensioner - Fig 19

6. Fit PAS belt  - Fig 19

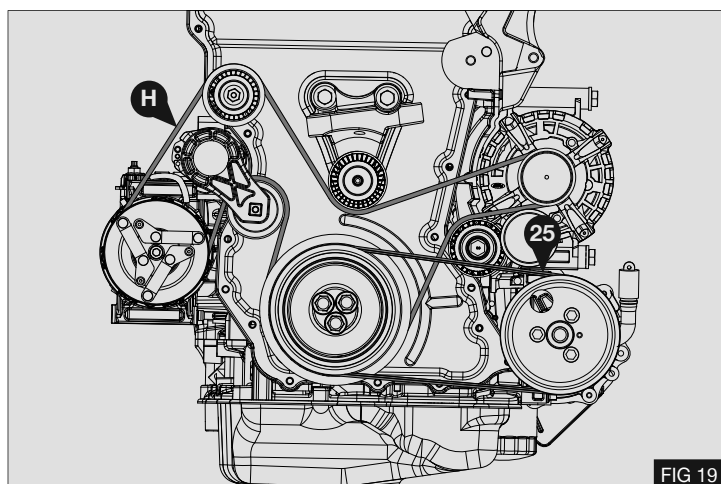

## FRONT AND REAR SUPPORTS

1. Remove and discard the 2x studs (X) from the engine mount  
- Fig 20

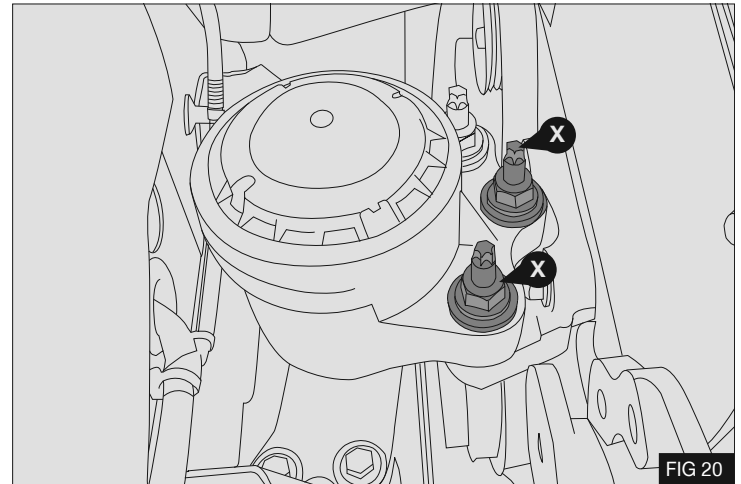

FIG 20

2. Fit front support (1) using 2x M12x130 bolts (14) with washers (20) and 2x M10x30 bolts (9) - Fig 21

Torque bolts (14) to 115Nm / 85Lbft

Torque bolts (9) to 58Nm / 42.8Lbft

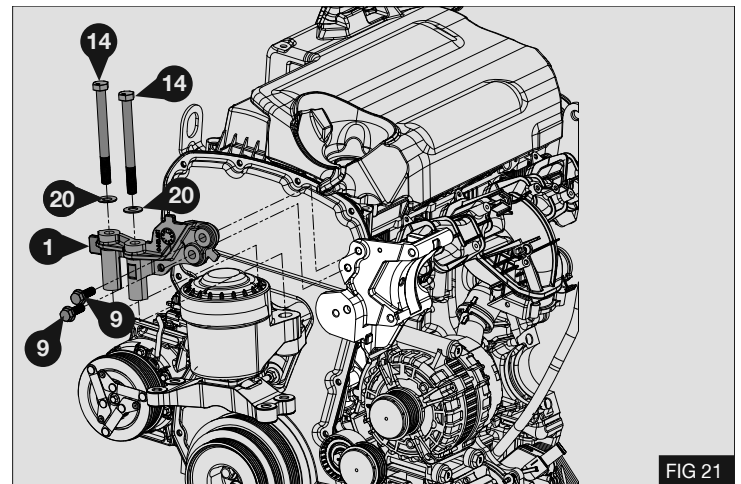

FIG 21

3. Modify refrigerant compressor (Z) by carefully removing the mounting lugs indicated - Fig 22

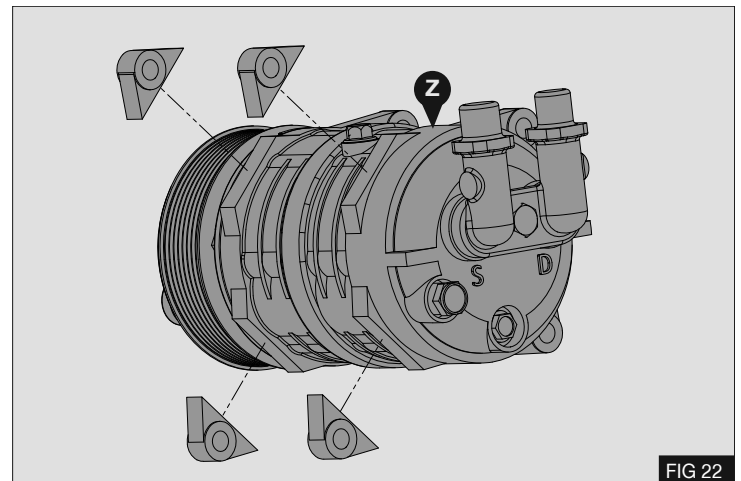

FIG 22

4. Fit modified compressor (Z) to the main bracket (3) using 3x M10x30 bolts (9). Do not fully tighten the bolts at this stage.  
- Fig 23

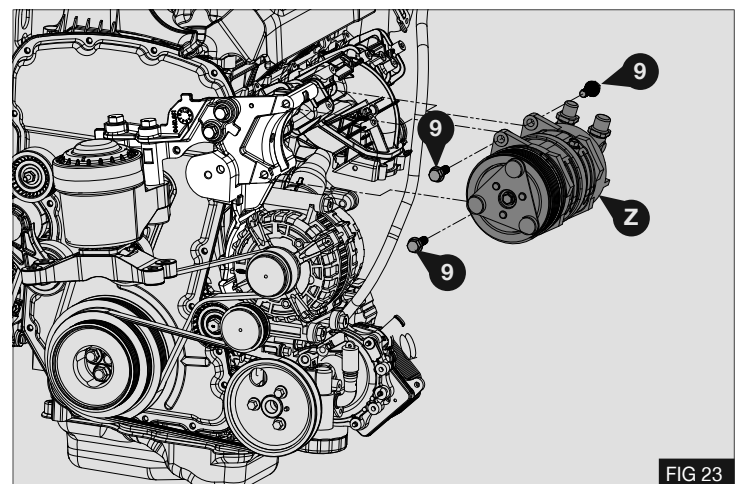

FIG 23

- Fit the rear support (2) using 1x M8x50 bolt (12) and 1x M10x60 cap head bolt (11) and washer (10) - Fig 24

Torque bolts (9) to 58Nm / 42.8Lbft - Fig 23

**Note:** : Torque the bolts at the front of the compressor first.

Torque bolt (11) to 58Nm / 42.8Lbft

Torque bolt (12) to 29Nm / 21.4Lbft

- Reconnect alternator wiring harness

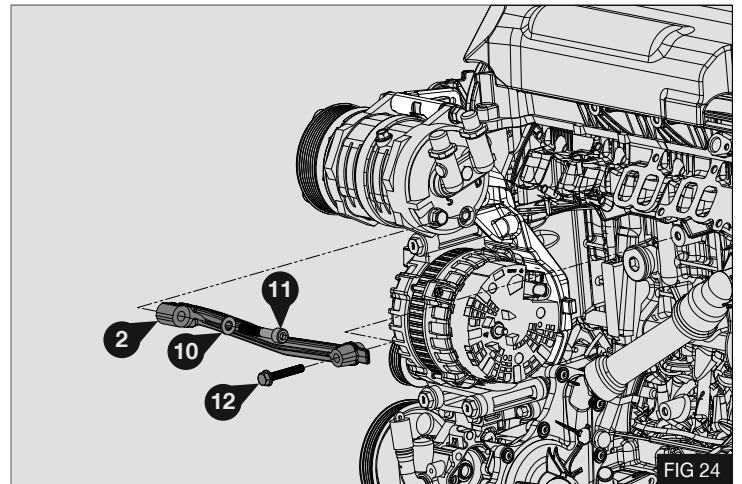

### COMPRESSOR BELT

- Assemble the pulley (32) onto Adjuster plate (8) with M8 x 30 bolt (31) Spacer (29) and Pulley nut (30). - Fig 25

Torque bolt (31) to 29Nm / 21.4 lb.ft

- Fit adjuster base (4) with plate (8) to bracket (3) secure using M10 x 60 Cap head bolt (11) and Washer (10). During this operation align dowel in adjuster base (4) with the corresponding hole in bracket (3). Install M8 x 30 bolt (31) with M8 washer (28) through the slot in adjuster plate (8) and into adjuster base (4). - Fig 25

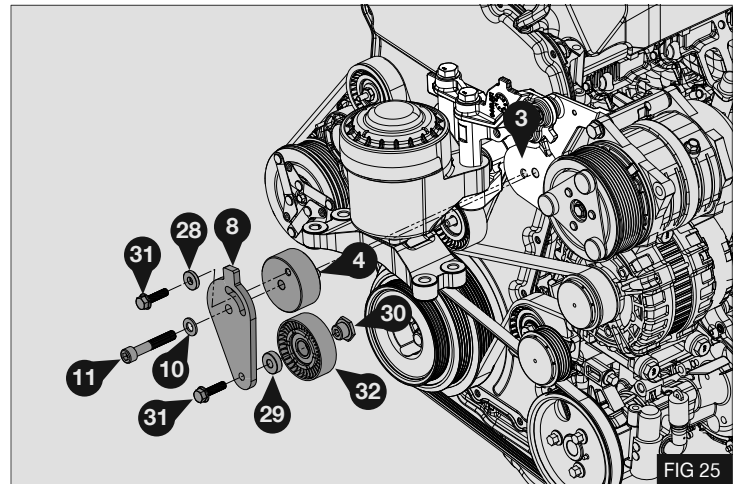

- Install the compressor belt (26) - Fig 26

- A - Crankshaft Pulley
- B - Tensioner Pulley
- C - Compressor Pulley
- D - Idle pulley

BELT TENSION TABLE		
Belt	Belt Age	Belt Tension Using Belt Tension Gauge
4PK	New Belt	48 - 56 kg
4PK	Used Belt	36 - 40 kg

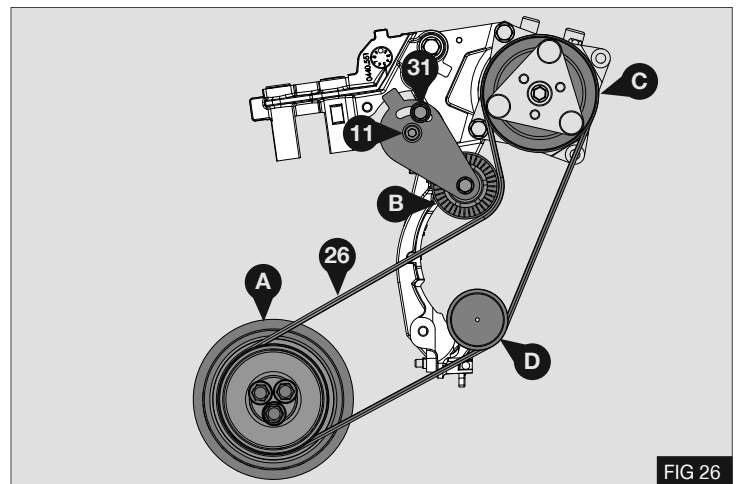

- Ensure the belt is positioned into the correct grooves. - Fig 27

- TM / QUE / SANDEN: Compressor must be PV8 with a G/L of 46.55 (see applications table on page 6.)

- Tension drive belt (26), once correct tension is achieved (see table on page 15) tighten Cap head bolt (11) and M8 Bolt (31). - Fig 26

Torque bolt (11) to 58Nm / 42.8 lb.ft

Torque bolt (31) to 29Nm / 21.4 lb.ft

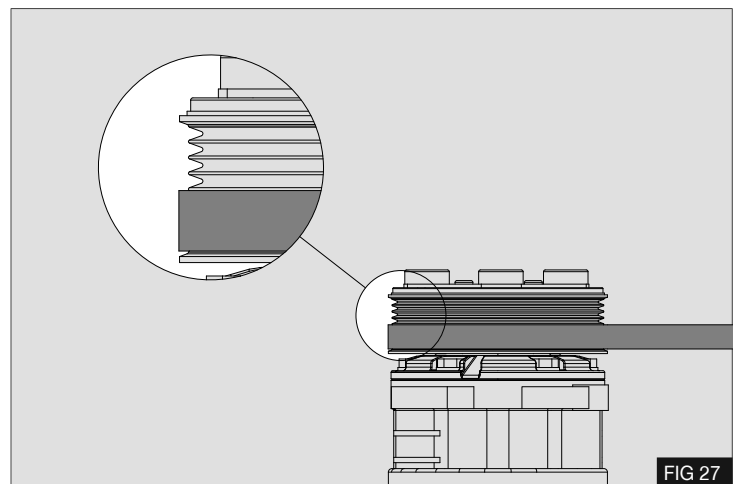

**INTERCOOLER HOSE**

1. Modify the intercooler duct (E) by carefully removing 25mm from end indicated, fit modified hose to vehicle with new clip (23)  
- Figs 28/29

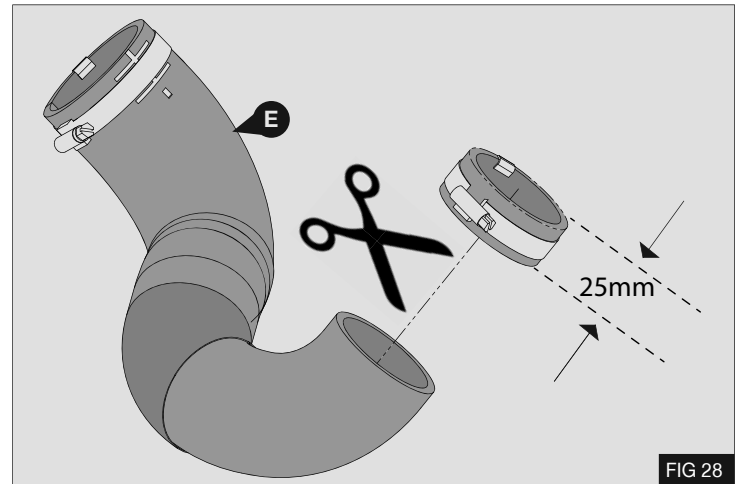

**Caution:** Check clearance (A) 8-10 mm required. It may be necessary to re-orientate the connection at the manifold to obtain sufficient clearance. - Fig 29

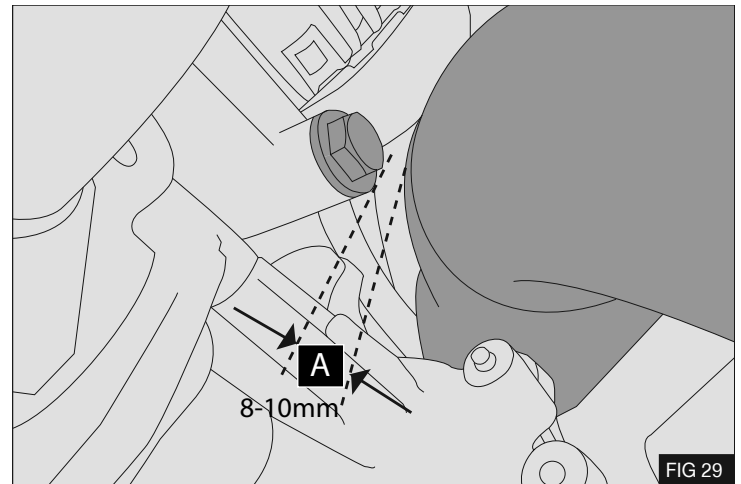

2. Secure harness connector (Q) to the hole in bracket (3) using M6x16 bolt (16) - Fig 30

Torque bolt (16) to 10Nm / 7.5Lbft

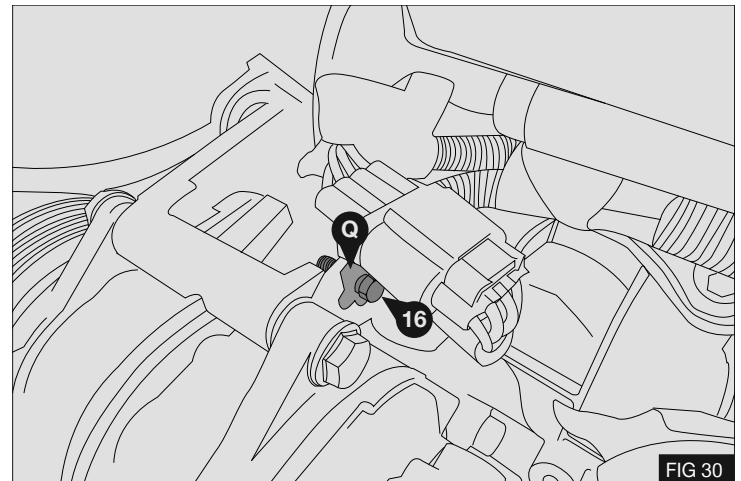

**PAS HOSES**

1. Remove and discard PAS reservoir mount (Z) – retain fasteners (Z1) - Fig 31

**Note:** IMAGE MAY NOT REPRESENT VEHICLE MODEL

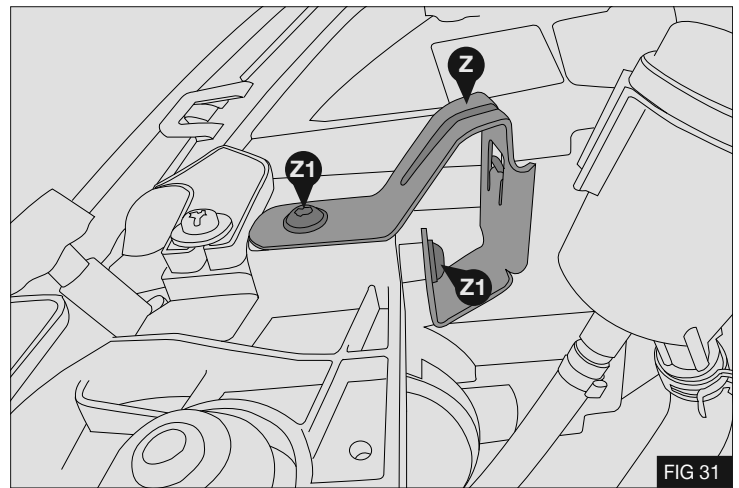

2. Re position Low pressure PAS hose behind the coolant hose. - Fig 32a/b

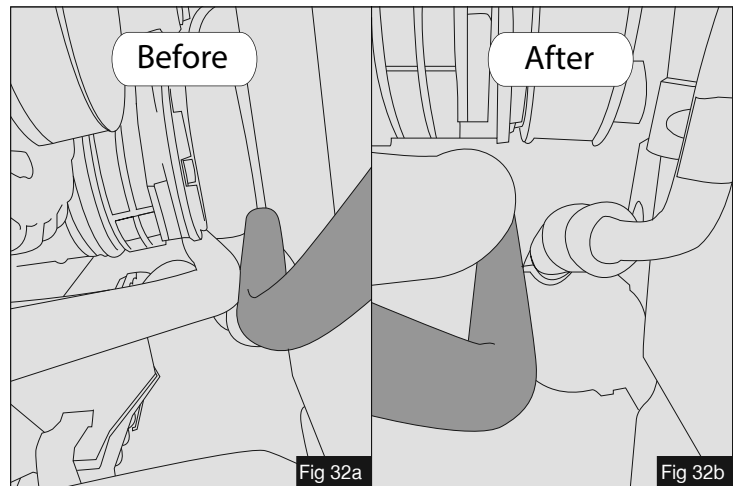

3. Re-position coolant hose clip (C1) - Fig 33 a/b

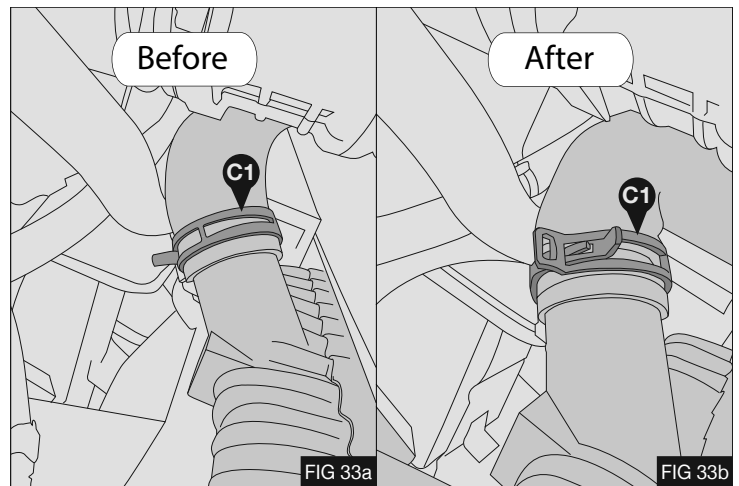

4. Fit PAS mounting bracket (24) using the original screws (Z1) - Fig 34

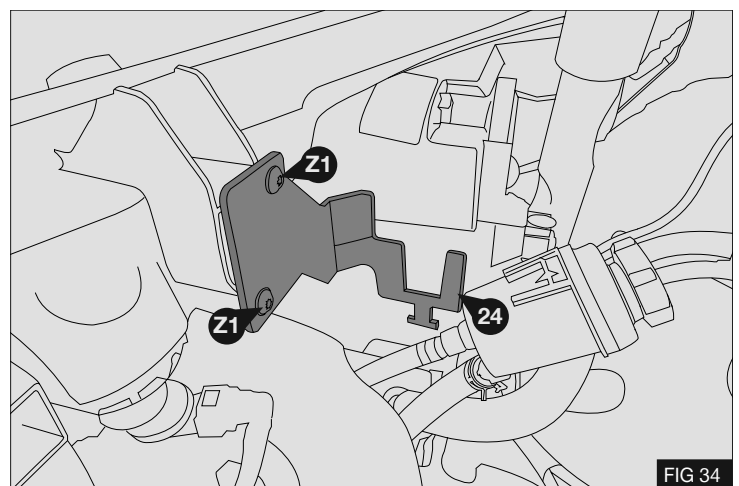



5. Fit PAS reservoir (22) to bracket (24) using hose clip (23)  
- Fig 35

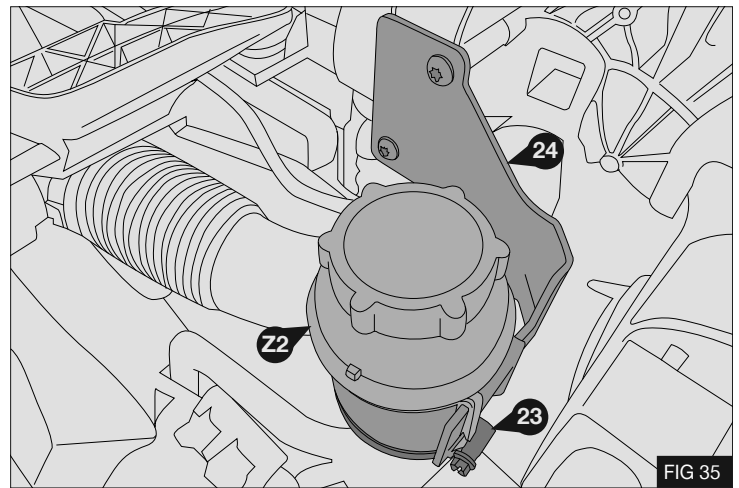

6. Fit protective sleeve (27) to PAS hose. - Fig 36

**Note:** Position sleeve in the most suitable place to protect the hose.

7. Re-fit all parts previously removed.

#### POST INSTALLATION

1. Before starting the engine check all the installed parts and ensure that the belt is installed correctly. Run the unit for at least ten minutes, then check the whole mounting assembly and previously removed parts. Attach the supplied warning label on to a suitable location.

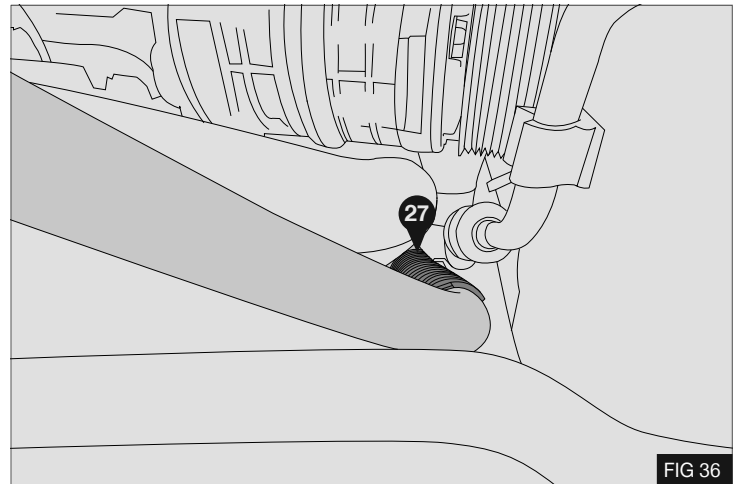





(EN)

Techni focuses on constant upgrading of its products. The Manufacturer reserves the right to modify the models and components described in the present publication at any time for technical or commercial reasons and without prior notice. For further information, contact Techni technical services.

(DE)

Techni ist stets bestrebt die eigenen Produkte zu verbessern. Die Herstellerfirma behält sich das Recht vor, aus technischen oder Verkaufsgründen, zu jeder Zeit und ohne vorherige Ankündigung, Abänderungen an den Modellen und den in dieser Veröffentlichung beschriebenen Einbauteile vorzunehmen. Für weitere Informationen bitten wir Sie, sich an unseren Techni Kundendienst zu wenden.

(FR)

Techni vise à une amélioration constante des ces produits. La maison se réserve le droit d'apporter, à tout moment et sans préavis, des modifications aux modèles et aux composants décrits dans cette publication pour des raisons d'ordre technique ou commerciale. Pour d'ultérieures informations s'adresser au service d'assistance Techni.

(IT)

Techni mira ad un costante miglioramento dei propri prodotti. La Casa si riserva il diritto di apportare in qualunque momento e senza preavviso modifiche ai modelli e ai componenti descritti in questa pubblicazione per ragioni di natura tecnica o commerciale. Per ulteriori informazioni rivolgersi al servizio assistenza Techni.

(ES)

Techni aspira a un constante mejoramiento de su producción. La Fábrica se reserva el derecho de aportar en cualquier momento y sin preaviso modificaciones a los modelos y los componentes descritos en esta publicación por razones técnicas o comerciales. Para ulteriores informaciones dirigirse al servicio asistencia Techni.

VENDITA E SERVIZIO  
VENTE ET SERVICE

SALE AND SERVICE  
VERKAUF UND SERVICE



Sundorne Trade Park, Henley Way,  
Shrewsbury, United Kingdom, SY1 4NS  
Telephone (+44) (0) 1743 443176  
Fax (+44) (0) 1743 443113  
Email: [sales@techni.co.uk](mailto:sales@techni.co.uk)